



Federal Ministry
for Economic Affairs
and Energy

ICT for Electric Mobility III

*Integration of commercial electric vehicles
into logistics, energy and mobility infra-
structures*



Imprint

Published by

Federal Ministry for Economic Affairs and Energy (BMWi)
Public Relations
11019 Berlin
www.bmwi.de

Current as at

July 2018

Print

MKL Druck GmbH & Co. KG, Ostbevern

Design

PRpetuum GmbH, München

Image credit

BMWi / title

Gettyimages

3alex / p. 10

Bartek Szewczyk / EyeEm / p. 9

Hero Images / p. 12

JGI/Jamie Grill / p. 6

Monty Rakusen / p. 4

Westend61 / p. 46

You can obtain this and other brochures from:

Federal Ministry for Economic Affairs and Energy,
Public Relations Division
Email: publikationen@bundesregierung.de
www.bmwi.de

Central ordering service:

Tel.: +49 30 182 722 72

Fax: +49 30 181 027 227 21

This brochure is published as part of the public relations work of the Federal Ministry for Economic Affairs and Energy. It is distributed free of charge and is not intended for sale. The distribution of this brochure at campaign events or at information stands run by political parties is prohibited, and political party-related information or advertising shall not be inserted in, printed on, or affixed to this publication.

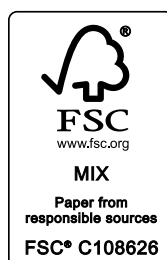

Content

Introduction	2
1. The road to the “ICT for Electric Mobility III” technology programme	5
2. Meta- and key topics	7
e-Fleets and logistics	7
Energy and data	7
Business models, profitability and user acceptance	8
Laws and regulations	8
Data capture and processing	8
Standardisation	9
Vehicle concepts and infrastructure	10
Fleet management	10
Energy and battery management	11
3. Projects of the Programme	13
3connect	13
Adaptive City Mobility 2	14
ALEC	15
charge4C	17
DiTour-EE	18
eJIT	20
eMobility-Scout	21
GridCON	23
GridCon2	24
Hub Chain	26
iHub	27
iMove	29
lokSMART Jetzt! 2	30
MENDEL	32
OVAL	33
PostBot-E	35
RouteCharge	36
SADA	38
Smart Distribution Logistik	40
sMobilityCOM	41
UrbanMove	43
WINNER	44
4. Supporting research	47

Introduction

Today's mobility concepts are not sustainable. In conurbations, people suffer from traffic jams, air pollution and noise that endanger their health. Conversely, public transport connections in rural areas are being increasingly thinned out. New forms of mobility are absolutely essential. They include new vehicle drives as well as innovative traffic control and an intelligent energy supply. The traditional notion that each vehicle communicates only with itself is just as much at issue as the habit that a vehicle should only be used by its owners. Sharing concepts and intermodal solutions are gaining in importance. The possibility of generating regionally and optimally redistributing the electricity that drives electric vehicles opens up new perspectives. The change in our mobility habits is a profound social challenge. Implementing it means leaving old patterns behind and promoting disruptive innovations.

The German Federal Government is keen to actively shape this change and together with actors from industry, science and society, to ensure climate-friendly and cost-effective mobility that benefits all people. To support the introduction of electromobility in particular, the National Platform for Electric Mobility (NPE) was established. As the future platform "Future of Mobility", it will work to implement mobility concepts of the future as efficiently and effectively as possible across technologies. Information and communication technologies (ICT) play an integrating role in bringing vehicles, transport and energy together to form an overall electromobility system.

Since 2009, the Federal Ministry of Economics and Energy (BMWi) has therefore initially funded research projects on the basic information and communication technology aspects of electric mobility as part of the "ICT for electromobility I" funding programme. The projects of the "ICT for Electric Mobility II" programme were already aimed at marketable products and services. The "ICT for Electromobility III" funding programme now focuses on commercial electric mobility solutions, as the logistics sector and commercial transport continue to produce rising CO₂ emissions while private transport emissions are slowly falling. On the other hand, electric mobility in commercial transport can already be implemented profitably today under suitable circumstances if it is accompanied by an intelligent combination of modern traffic management systems (Smart Traffic), future energy systems (Smart Grid) and innovative architectural and vehicle concepts (Smart Car).

Freight transport journeys usually take place on regularly recurring routes. They generally cover very high mileage per year and can be planned efficiently. For electric vehicles used in logistics, the amount of power required and the optimal locations for recharging the traction battery can be calculated in advance. Intelligent control systems can anticipate and optimise the flow of traffic. A traffic control system that communicates with vehicles and energy networks will bring electric vehicles to their destination in the best possible way. Electric vehicles that meet their energy needs with the help of intelligent energy management will not only deliver their goods on time, but also optimize their battery usage. The fluctuating, weather-dependent generation of energy from renewable energy sources can be made relatively stable through smart ICT solutions and storage systems. The vision of vehicles making their battery capacity available to the power grid during periods of standing time is within reach. Conversely, if the electricity grid were to provide electric vehicles with excess energy when needed, it could buffer supply and generation peaks.

Many additional services that serve the protagonists of commercial transport to improve their performance can be integrated into traffic control, energy management and vehicle control via open interfaces. Open interfaces and standardization are therefore basic requirements in all projects presented here. Data security has the highest priority at all times.

The synergies that the projects presented here aim to achieve are forward-looking and have already aroused great interest among investors and users. The projects range from electric tractors in agriculture and freight traffic on loading ramps to electric taxis that are to be operational around the clock. Autonomous driving for the transport of people and goods is also being researched.

Electric mobility as a link between electricity generation from renewable energy sources and the transport sector is an important component of the energy transformation. It contributes significantly to integrated energy. The aim is to gradually replace fossil fuels with renewable energies not only in the electricity sector but also in the heating, cooling and transport sectors. ICT solutions will play a decisive role in this process and help to reduce emissions and link and optimise logistics, energy and mobility infrastructures. Germany's contestability and prosperity will also depend on the successful linking of these key sectors.



1. The road to the “ICT for Electric Mobility III” technology programme

Modern information and communication technologies (ICT) play an important role in electric mobility. They control all important functions in the electric vehicle and form the basis for its integration into intelligent energy and transport systems. ICT are therefore the prerequisite for a functioning overall electric mobility system.

In view of the importance of ICT as the key to the success of electric mobility, the BMWi initiated the “ICT for Electromobility I” funding programme in 2009. By autumn 2011, seven model projects had demonstrated and tested prototypical and economical solutions for the integration of electric mobility in intelligent networks and the incorporation of renewable energies in field trials. The focus was on the development and testing of open system approaches in which electric mobility is optimally integrated into transport and energy networks. In particular, ICT-based charging, control and billing infrastructures as well as business models, services, norms and standards based on them were examined. The results made it clear that the chances of success of electric mobility in Germany can be increased if the previously largely separate areas of vehicle, transport and energy are systematically brought together by ICT.

Based on this finding, the BMWi funded a total of 18 projects between 2012 and 2015 in the “ICT for Electric Mobility II: Smart Car – Smart Grid – Smart Traffic” technology programme, the aim of which was to develop new concepts and technologies for the interaction of intelligent vehicle technology in electric cars (smart cars) with energy supply (smart grid) and traffic management systems (smart traffic) based on ICT. This resulted in much-noticed results and recommendations for action, which were published in the “Position Paper on ICT for Electric Mobility” in spring 2015, among others.

With the technology programme “ICT for electromobility III: Integration of commercial electric vehicles in logistics, energy and mobility infrastructures”, the BMWi is continuing its technology programme with a focus on electric mobility

for commercial use. A study commissioned by the supporting research on “ICT for electromobility II” showed that there is particularly great potential for the introduction of electric mobility in this area (up to 700,000 commercial electric vehicles by 2020). In the period from 2016 to 2020, the BMWi will therefore support 21 projects that develop exemplary system solutions for the commercial sector and integrate technologies, services and business models.

The primary objective of the new funding programme is to identify economically viable applications of electric mobility in the commercial vehicle segment and to help them achieve a breakthrough. As in the previous programmes, the focus is not on the development of electric vehicles and their drives themselves, but on their integration into ICT-based, holistic logistics, energy management and mobility concepts. To this end, suitable technologies are to be developed in the projects and tested in practical use.

The research work of the funded projects focuses on three main topics:

- **Logistics:** electric commercial vehicles and passenger cars for commercial use
- **Energy:** Integration of commercial electric mobility in energy networks and smart grids
- **Mobility:** Intelligent integration in holistic mobility, platform and logistics concepts in connection with new vehicle technology

In order to do justice to electric mobility as an overall system, the “ICT for electromobility III” funding programme does not tackle its three main topics in isolation. Rather, these focal points are often already being worked on across projects in the sense of a systemic approach. Furthermore, they are considered and analysed synoptically by the supporting research of the funding programme.

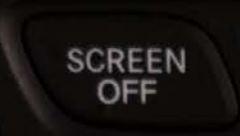

2. Meta- and key topics

Under the umbrella of ICT as the key to a successful entry into an overall electromobility system, two metatopics have emerged from the projects of the “ICT for EM III” funding programme:

e-Fleets and logistics

Projects in the metatopic „e-Fleets and logistics“ deal with commercially utilised scenarios of ICT-based coordination, control and mission planning. In this context, the specific characteristics of the fleets used and their logistical application must be taken into account. A precise knowledge of the status quo (battery capacity, route planning, traffic situation) is crucial for the development of sustainable solutions as well as a forecast. This allows optimising the profitability of electric vehicles in commercial fleets.

The focus is on the following applications:

- Intra-logistics (e.g. company premises, airport, port)
- Distribution logistics
- Company fleets, especially those of care services
- Agriculture and building industry
- Public transport including innovative e-taxi and fleet concepts

Energy and data

The projects in the metatopic Energy and Data deal with the optimal coordination between energy generation and storage. On the one hand, the (renewable) electricity supply from both local and national grids and, on the other hand, both mobile and stationary electricity storage facilities are taken into account. This might include e.g. a decentralised link between electric vehicles and “Smart Facilities”, or the integration of entire vehicle fleets into the energy systems of businesses and companies or neighbourhoods/industrial estates. Again, optimised mission planning relies on comprehensive knowledge of the current status as well as the best possible forecast. This requires open communication with vehicles as well as the development of manufacturer-independent interfaces for improved networking of electric vehicles and traffic infrastructure.

The focus is on the following applications:

- Development of economically viable models for controlled charging and recovery
- Broader linkage towards local Smart Grids by including a range of generation plants and controllable loads
- Improved networking of electric vehicles with traffic infrastructure as well as highly automated driving

Illustration 1: Meta- and key topics of the ICT EM III programme

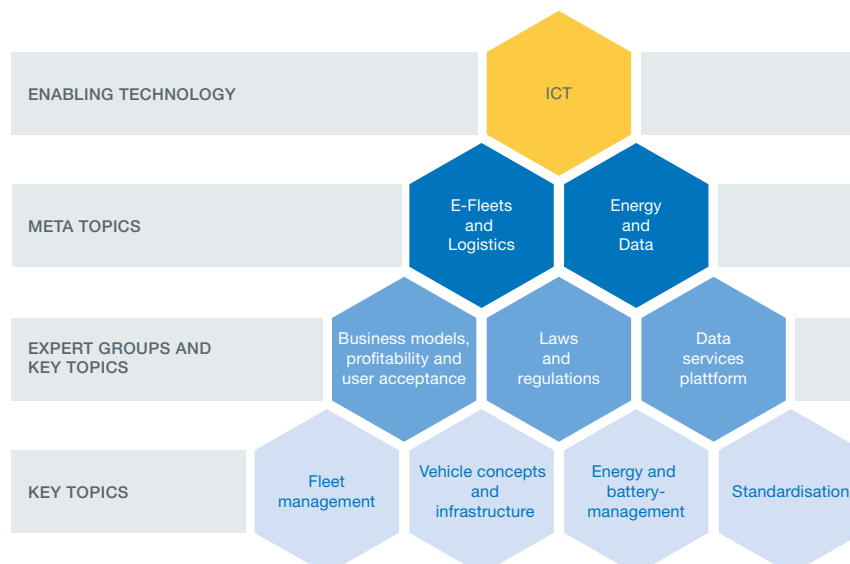

- Forecasting and effective control of swarm behaviour
- Processing of real-time data for vehicle position and destinations as well as information from networked sensors in tactile roads
- ICT-based intermodal mobility concepts
- Data fusion architecture for shared utilisation of sensor data
- Further development of platform technologies and cloud solutions

Seven key topics are derived from the two metatopics, on which the projects conduct research and which they develop further together with the accompanying research in expert groups and task forces.

Business models, profitability and user acceptance

A lack of business models still represents a major barrier for electric mobility into the commercial sector. The economic efficiency alone determines the decision to buy and user acceptance. However, the total cost of ownership (TCO) still seems far too high to most entrepreneurs. It is therefore important to calculate the TCO realistically and reliably while at the same time reducing it to a level that is competitive with conventional drives.

The relatively high purchase price and the still limited ranges must first be offset by the significant savings that can be achieved with electric commercial vehicles. These savings are due to lower operating and maintenance costs and slower wear of electric vehicles. However, financial advantages can also arise in the future through the integration of electric vehicles into a smart grid if their batteries provide control energy for the electricity markets in the future or, conversely, buffer supply peaks. In addition, battery change concepts for taxis and delivery services, for example, can pay off positively.

It is also advantageous for operators of a commercial fleet not only to optimise the use of electric vehicles according to conventional conditions of vehicle scheduling, but also to include loading times, quantities and locations. The “ICT for Electric Mobility III” technology programme is developing suitable processes for this purpose. At the same time,

further savings potential exists in bundling several fleets, the joint use of IT platforms, the combination of passenger and goods logistics and cooperation with traffic management systems. From the point of view of economy, some projects take a bird’s eye view and consider the overall system of commercial electromobility for a particular region.

Laws and regulations

Commercial electric mobility affects a large number of legal areas, including energy law, calibration law, tax law, data protection law and liability law. Rapid technical progress repeatedly creates situations that are not adequately taken into account in existing legislation. The key topic of laws and regulations therefore deals with the effects of current legislation and regulations and the development of proposals for their interpretation, further development and modernisation. After all, legal planning security is a central prerequisite for the successful introduction of electromobility.

The projects provide a wide range of practically relevant scenarios for the concrete discussion of legal issues. For example, what impact does it have on data protection when systems in the vehicle, in the traffic infrastructure, in the driver’s smartphone, in the fleet operator’s server and in third-party vehicles constantly exchange data on a large scale? How can a possible preference of electric vehicles in traffic management be justified? How can an EU directive on the ad hoc use of charging points be implemented? What legal scope exists for the design and use of different types of connection to the smart grid? How can the rapid development of different forms of loaders be harmonised with the long legislative procedures of calibration law?

In dealing with this key topic, it is not only a matter of an exchange of the projects with one another, but in particular of providing consensual, technically relevant foundations and recommendations for legislation.

Data capture and processing

Commercial vehicles are only economically worthwhile if they achieve a high degree of utilisation. This applies in particular to electric vehicles. Planning their use as efficiently as possible is therefore essential from a business point of view. This will become easier and easier through the use of innovative ICT, but places high demands on reliability, IT security and data protection (privacy).



ICT solutions for recording and processing large amounts of data, for example from sensors and navigation systems in the vehicles of a fleet, from the course of battery charging processes or from traffic management systems, are developed in numerous projects. The intelligence of the overall system arises, among other things, from the ability to link data from different components, sometimes unknown in advance, in order to control fleet planning.

To turn such solutions from prototype to public domain, projects in ICT for electromobility III develop appropriate technologies, including a middleware architecture that replaces and extends beyond common bus systems in the vehicle, as well as tools for comprehensive data exchange between fleet operators, traffic management systems and power grid operators. In other projects, widely usable cloud-based ICT components with open interfaces are programmed, which can be used, for example, to communicate with power exchanges with little effort.

The variety of application scenarios in the projects makes it possible to review and refine the results from this key topic directly in practice. This ensures that they have a lasting effect beyond the funding measure.

Standardisation

Standardisation is particularly important in commercial electromobility. As many different players work together in this area, including vehicle manufacturers, suppliers, fleet operators, energy suppliers, municipalities, drivers, ICT providers and public transport companies. This implies not only in the business processes, but above all at the technical level a multitude of interfaces, which must be standardized. In order to accelerate the transfer of project results into further processing, it is indispensable to deal intensively with current and planned standardization activities and to identify and close possible gaps in them.

The key topic deals among other things with communication between vehicle, vehicle battery and infrastructure. Applications include, for example, cross-fleet reservation and booking processes, blocking charging points, an intelligent charging infrastructure for E-buses, battery change stations, the integration of apps into cloud solutions using standardized programming interfaces (APIs) and stationary and mobile buffer storage. Agricultural technology plays a pioneering role for this key topic, in which standards have been established for years and can now be expanded.

In particularly complex applications, standardization is sometimes not the most feasible way forward, but rather the development of suitable intermediate applications (middleware) as “translators” between different technical worlds. This is also being researched in ICT for electromobility III projects.

As in other key topics, the wide variety of areas of application and application scenarios in the projects makes it possible to develop results of general relevance that can trigger or enrich comprehensive standardization processes.

Vehicle concepts and infrastructure

Electric mobility does not simply mean replacing combustion engines with electric motors. Rather, it opens up the opportunity to rethink and develop vehicle concepts from scratch. This applies in the commercial sector for passenger cars and light delivery vehicles as well as for buses, taxis, medium-duty trucks, semitrailers and agricultural machinery.

One of the projects is testing a new concept for inner-city passenger and freight transport, for example, with an innovative vehicle platform that covers both modes of transport in variable configurations: in the case of taxi passenger transport, it can be precisely adapted to demand and is thus considerably more cost-effective than conventional or converted taxis.



Considerable technical development work is also required for medium-weight trucks and semitrailers, as there is currently no significant product range on the market. Some projects in ICT for electromobility III combine the construction of such vehicles with field tests over short to medium distances (up to 300 km), whereby on short distances the optimal dimensioning and placement of charging stations and on medium distances battery change stations play an important role.

The development of new vehicle concepts is spurred on by the fast and reliable exchange of data between components within the vehicle. This is all the more true when driving functions are to become autonomous with the aid of powerful sensors and real-time processing of large data streams. One of the projects enters double new territory with an all-electric and highly autonomous semi-trailer. Overall, the implementation of new vehicle concepts and their integration into a suitable infrastructure places high demands on sensors, functional safety and electromagnetic compatibility (EMC).

Fleet management

Electromobility already pays off today if the capacity utilization of the vehicles and the route profile match the vehicle. This applies to commercial electric mobility in particular when it comprises not just a single vehicle, but an entire fleet that is systematically controlled by one operator. For this purpose, optimal traffic modelling is required as a basis for forward-looking predictive disposition planning. For example, one of the projects is testing the integration of electric trucks into the fleet of a large logistics company, in which electric trucks and conventional trucks can play to their respective strengths. As a long-term goal, complete electrification of the vehicle fleet is to be made possible.

Using standardized cloud solutions, vehicle scheduling and energy and load management can be developed and implemented for several fleets at once, which can lead to significant economies of scale with corresponding cost reductions. Fleets can also be used particularly economically if they follow complementary usage patterns: For example, their vehicles are used by a nursing service during the day and by a security service at night.

However, it is not enough to achieve an optimum for the entire system only theoretically. The decisive factor is that this optimum does not collapse in the event of malfunctions (traffic jams, technical defects, etc.), but rather ensures

stable operation. Intensive data exchange with and between the individual vehicles and the consideration or even influencing of traffic flows help to achieve this goal. A prerequisite for this is the availability of all necessary data, ideally in real time.

The projects in ICT for electromobility III meet this challenge in field tests with very different fleets: from a handful of vehicles up to a three-digit number, from small commercial enterprises to global logistics companies, from operation on company premises to transport on public roads.

Energy and battery management

Electromobility as an overall system thrives on intelligent control of energy flows between vehicles, stationary storage facilities, local energy sources and the public power grid. Thanks to their batteries, electric vehicles can also be used as mobile storage devices, making them an important component of the grid stability that is becoming increasingly important in the wake of the energy transformation. Therefore, the coupling of electric vehicles with the smart grid, smart homes and smart farms is examined in this key topic. Solutions for other challenges in electric mobility are also being developed and tested, such as demand side management, grid usability, bidirectional DC charging, rapid charging and integration of renewable energies.

What can ICT tools contribute to solving these problems? On the one hand, they can ensure that the right vehicles are available at the right time with the right (minimum) charge level in coordination with the mission planning of a fleet. They can also make the best possible use of the supply and load curves of the power grid (possibly with the aid of stationary storage facilities). In this way, charging processes can be controlled so intelligently that in times of low consumption surplus energy from renewable sources is used to supply e-vehicles and electricity is fed back into the grid from vehicle batteries during times of high consumption. Every intelligent controller must take care to handle the vehicle batteries carefully, i.e. to keep their wear as low as possible.

Several projects in ICT for electromobility III are concerned with the development of such intelligent controls for energy and battery management – partly at local, partly at regional or even supranational level. Battery replacement concepts are also being researched. In order to test the performance of the software for energy and battery management, field trials and extensive simulations will be carried out, the results of which will be valuable beyond the technology programme.



INFLUENCE

TRENDS

QUALITY

best

Active



3. Projects of the Programme



3connect

Electric mobility in fleets, logistics, public transport and agriculture - interoperable and networked between mobility and energy

Illustration 2: 3connect combines e-mobility from agriculture, public transport and delivery services

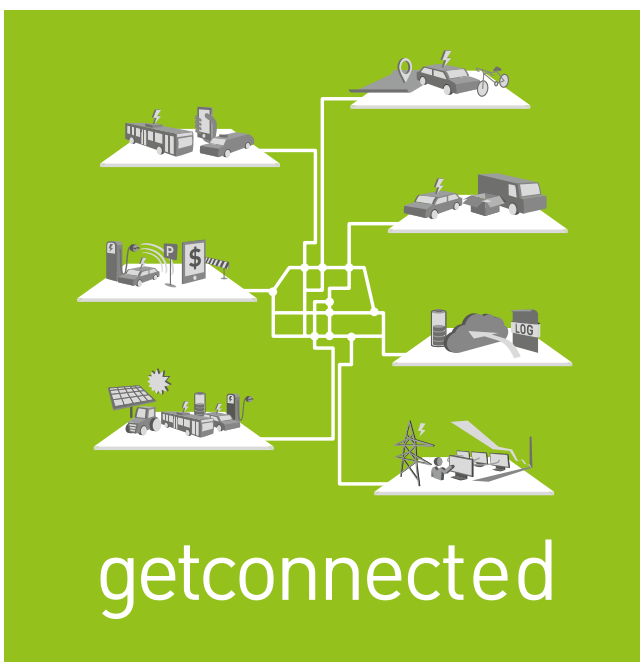

Source: Project 3connect

The Challenge

Many parts of the value chain of commercial electric mobility – from power generation and vehicle technology to infrastructure components – have so far been working side by side without any connection. These parts are now to be networked in order to boost the efficiency of electric mobility as well as the energy markets. Networking should be standardized in order to produce interoperable, open solutions that are inexpensive, compatible and precisely tailored to almost any electro-mobile requirement.

The approach

At three locations (hubs), 18 partners are developing ICT-based applications. All the emerging components and systems feature several interfaces to allow a plug&play combination of both hardware and software.

The Osnabrück partners are creating an app-based e-mobility platform. It brings together real-time data from electric car and pedelec sharing, electric taxis, charging points, public transport and the grid, and provides users with an integrated mobility offering. The Aachen team is designing intelligent grids and energy markets for commercial logistics. In the Allgäu region, project partners are implementing solutions for agriculture as well as for municipal and commercial deployment.

Target users and benefits

Due to the compatibility of the components, the target group includes all protagonists of the electric mobility market: from energy generators to public transport providers with electric busses, companies, municipalities, fleet operators and managers, electric car sharing services and Pedelec hire firms, farmers, parking space providers, charging point operators and many others.

Energy

Interlinking e-mobility with the energy grid serves the optimal distribution and use of energy. As an example, intelligently storing and feeding in electricity can help to prevent critical grid conditions, increases the own consumption of photovoltaic electricity and ensures fully charged batteries in vehicles. The Smart Farm energy management system for hybrid tractors with its link to the energy market is an example of a practical application.

Networked communication

Energy suppliers and local energy management systems communicate via open interfaces. All electricity consumers – from electric vehicles up to municipalities – act as energy management systems. A comprehensively integrated communications and energy approach facilitates e.g. a free-floating e-car and pedelec sharing model and shows users where the next available vehicle is and how high its charge status is. The “CityNavigator” app provides interfaces that enable its use even for charging point and parking space

management, as a booking system and as a taxi dispatch service.

Opportunities for providers and users

With little effort, new integrated mobility offers can emerge, and new collaborations can grow between partners where previously a joint effort was almost unthinkable.



For further information:
www.3connect-projekt.de

Consortium partners

smartlab Innovationsgesellschaft mbH (Leader of the consortium), ABB AG, ABT Sportsline GmbH, Allgäuer Überlandwerke GmbH, cantaman GmbH, HaCon Ingenieurgesellschaft mbH, Hochschule für angewandte Wissenschaften Kempten, Innovationszentrum für Mobilität und gesellschaftlichen Wandel (InoZ) GmbH, John Deere GmbH & Co. KG, KEO GmbH, MENNEKES Elektrotechnik GmbH & Co. KG, Next Generation Mobility GmbH & Co. KG, regio IT gesellschaft für informationstechnologie mbH, RWTH Aachen, Schleppen AG, Stadtwerke Aachen AG, Stadtwerke Osnabrück AG, StreetScooter GmbH

Adaptive City Mobility 2 (ACM 2)



CITY eTAXI “Emission-free eMobility – a complete system for cities

The Challenge

Pressure from increasing traffic, dearth of parking spaces, CO₂ and particulate load require new approaches for traffic in cities. Project ACM develops an emission-free integrated approach for electric mobility applications in which mobility is shared as a publicly accessible resource: The guiding principle is “benefit instead of possession” based on the idea of “mobility as a service”.

The approach

The implementation becomes possible through three innovations. “E-Mobility light” represents a lightweight vehicle that is offered as part of a commercial fleet in a sharing model. A manual battery exchange system ensures that vehicles are “driving, not charging” and thus allows for a large range, e.g. in taxi operation. An operator platform intelligently integrates data from battery changing stations with user apps as well as the control software of the vehicles and thus optimises vehicle operation and utilisation. In E-CarSharing mode the choice (depending on transport requirements) is between the passenger car option with three seats, the mini cargo option, a van or a pickup. The three-seater is ideal as an electric taxi for the driver and two passengers including luggage.

Illustration 3: Design study of the City eTaxi



Source: Project Adaptive City Mobility 2

Target users and benefits

The vehicle represents a flexible and cost-effective mobility offering for private individuals as well as business users and supports a diverse range of requirements. The sharing approach and the innovative business model lead to cost savings for companies and private individuals when compared to running their own cars.

Energy

At just 500 kg, the lightweight L7E class vehicle is designed for city traffic. It reaches a top speed of 90 km/h and a range of approx. 120 to 140 km. When batteries are empty they are manually swapped for charged ones at battery exchange stations, then the journey can continue immediately. Ideally, the electricity comes from 100% renewable energies, which are generated on site on an adjacent roof surface with the help of a PV system, for example. Alternatively, the vehicle can be charged using a charging cable to ensure mobility even far away from a battery exchange station.

Networked communication

Reservation and booking systems, location- and user-aware customer information, route planning and the integration of payment systems are basic building blocks of the approach. The electric taxi configuration facilitates global and regional advertising and thus additional sources of revenue.

Opportunities for providers and users

The concept offers opportunities for those who want to drive cheaply or want to generate income by investing in battery change stations or renting vehicles.

The approach supports cargo transport by logistics and courier services, own-account transport, service traffic of tradespeople, of care, social, surveillance and security services as well as taxi and chauffeur services and municipal fleet operation.



For further information:

www.adaptive-city-mobility.de

Consortium partner

BMZ GmbH (Leader of the consortium), EuroDesign embedded technologies GmbH, Fraunhofer-Institut für Eingebettete Systeme und Kommunikationstechnik ESK, Green City Projekt GmbH, Plexiweiss GmbH, remoso GmbH, Roding Automobile GmbH, RWTH Aachen, Siemens AG, StreetScooter GmbH

ALEC – Alternation * Light * Electric * Construction



Universal battery-powered equipment carrier with tool changing system for change of operations activity on the airport apron

The challenge

On any airport's apron, many special purpose vehicles are in operation, but are reserved for just one single task. High capital lockup and long idle times, short driving distances, cold engines with poor emission levels and high maintenance cost are the consequence. Emissions from noise and pollution as well operating and investment costs shall be reduced. The ALEC project aims to deploy three vehicles capable of mastering these challenges at Erfurt Airport by 2020.

The approach

ALEC is developing a battery-electric vehicle, a so-called equipment carrier, with a tool changing system to manage various tasks on the airport apron. The equipment carriers can thus be deployed flexibly. Their service life is at least to be doubled compared to vehicles currently in use while their carrying capacity and traction is to be adapted to varying requirements. A fleet and vehicle energy management system will optimise operation and energy intake of the vehicles.

Target users and benefits

The number of vehicles on the apron shall at least be halved, resulting in lower investment and thus unlocking capital. The electric equipment carriers' lower energy and maintenance costs noticeably relieve the airport operators from day one. The environment, employees and passengers will also benefit from significantly lower noise and pollutant emissions. The latter can be brought close to zero when using renewable energies.

Energy

The airport apron has a high density of power connections. Essentially the vehicles could absorb energy wherever they stand. The concept vehicle envisages a scalable drive, converter and battery system resulting in 400 VDC and 48 VDC output voltages for powering both the vehicle and tools. The energy-optimising fleet management will include a grid-friendly fleet charging concept. The system also takes into account weather, radar and flight system data.

Networked communication

Open interfaces for mechanical, energy and software connections enable all tools to work on any equipment carrier using a uniform user interface. Sensor-based monitoring of the vehicle's surroundings will enable top accuracy in maneuvering and positioning. The resulting mapping and navigation of the airfield environment will be utilised for predictive and later for autonomous driving.

Opportunities for providers and users

Vehicles building on this flexible electric conversion kit offer variable wheelbases and vehicle lengths to meet changing requirements. Their carrying capacity and traction will be adjustable too. Airports thus require fewer vehicles, prepare their apron for autonomous vehicle operation and ensure their sustainability into the future.

Illustration 4: Multicar with various work tools





For further information:
www.alec-online.de

Consortium partners

HAKO GmbH (leader of the consortium), ACTIA I+ME GmbH, Flughafen Erfurt GmbH, MEG Mechanik GmbH, Navimatix GmbH, Fraunhofer IOSB – Institutsteil Angewandte Systemtechnik, Ostermann GmbH



charge4C

Smart sharing, parking, charging: Reservation platform for electric mobility

The challenge

Many people are interested in electric vehicles, but are still reluctant to purchase them, as charging possibilities are limited, especially in rural areas. There is also uncertainty as to whether the few charging stations available will be free at the required times. “charge4C” wants to address the problem with an electric charging station reservation platform that allows sharing of existing charging stations and increases charging station coverage. The platform is also intended to enable charging and parking processes to be priced dynamically, depending on electricity demand, and to bridge waiting times through offerings by local service providers.

The approach

By December 2020, an innovative sharing platform will be created that will enable parking and loading to be priced according to the state of the network. Communities and corresponding services around charging infrastructure in the private and public sector can be integrated into the platform, generate added value for the local retail trade and enable communication between people and technology in the urban environment. The intelligent platform records charging and parking profiles in order to develop forecasts for power requirements and parking space management. Charging capacities are calculated from the data on mobility behaviour, power load and power supply, which are not critical for the power grid and are released for the reserved charging stations according to the situation.

Target users and benefits

The user can benefit from optimized parking space management and value-added services provided by the community thanks to the concepts developed. For example, waiting times at the charging points could be reasonably bridged by local offers such as restaurant vouchers. In addition, citizens are increasingly involved in the development of the charging infrastructure. Service providers can use the intelligent platform to offer business models and reach customers.

Energy providers use the system to record parking and charging situations with the data obtained and to achieve optimum network utilization through dynamic pricing.

In inner-city areas, targeted and organised parking space management improves the flow of traffic and thus reduces environmental pollution. The additional expansion of the charging infrastructure and the associated services ultimately increases the attractiveness of a city.

Networked communication

The sensors and actuators on the charging station measure and control all parameters required for charging and network optimisation. Using real-time data and forecasting methods, particularly fine-grained measurement data can be recorded, processed and integrated into the control system. In addition, the platform organizes communication around sharing, parking and charging and offers the community access to

value-added services. An innovative app-based dialogue between man and technology is to enable users to monitor the state of charge and transmit further technical information.

Opportunities for providers and users

Charging point operators can transfer price models to locations with similar user behaviour and increase the utilisation of the charging points via the price model. The central system takes over the accounting, so that private providers or citizens' associations can also offer their charging points

in the system without additional effort of their own. Time-attractive charge current tariffs increase the acceptance of e-mobility, which supports the market ramp-up of emission-free mobility.



For further information:

<http://charge4c.de/>

Consortium partners

ampido GmbH, DFKI GmbH, Hakisa GmbH, Stadtwerke Saarlouis GmbH

Illustration 5: Overview graphic charge4C – Reservation platform for electric charging stations

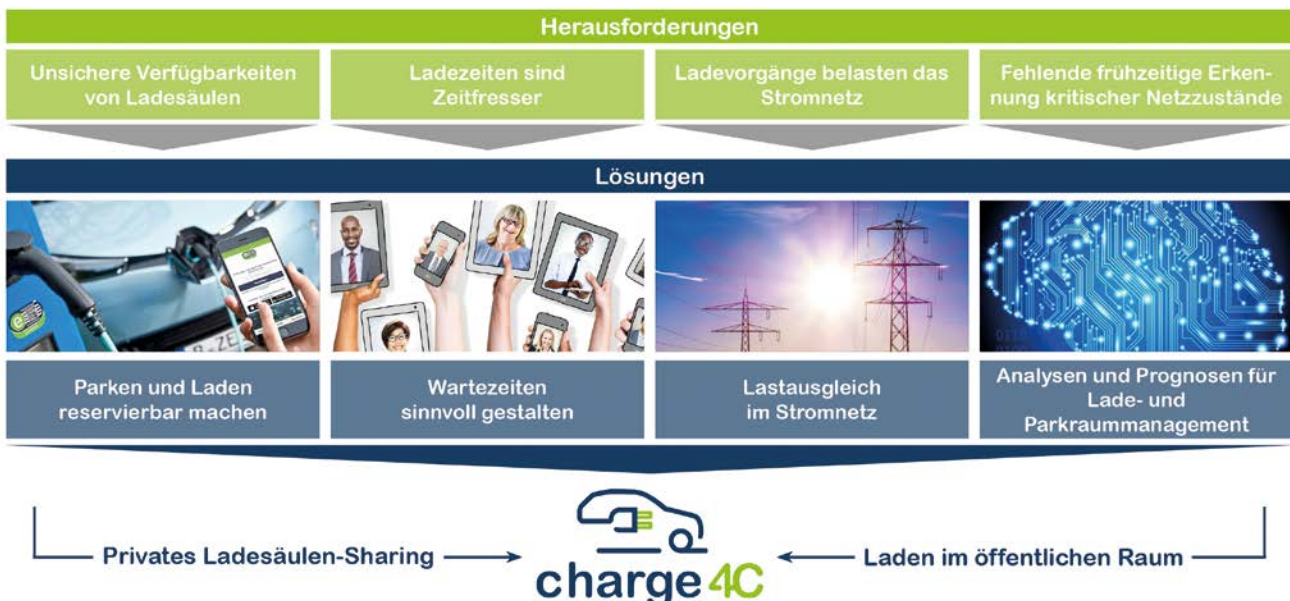

Source: Project charge4C

DiTour-EE



Digital solutions for smart tourism through coupling electric mobility and energy sectors

The challenge

If more and more hotel guests want to arrive with their own electric car and recharge their vehicles in the future, there is a need for hotels and tourist facilities to be optimised with regards to the installed load. Every guest wants

to head off with a full battery in the morning but the building connection's peak load should not be exceeded. Even offering touristic electric mobility services should be possible without overloading the hotels' energy management. DiTour-EE takes on this challenge and will present an ICT-based solution in December 2020.

The approach

An IT platform connects tourism and gastronomic mobility services. Taking into account forecasts of energy demand it will include flex, load, and energy management services. Control strategies optimize the building's energy costs and power output and ensure the vehicles are charged. The platform also integrates guests who can book e-mobility offers via interfaces.

Target users and benefits

Hotels und guests benefit from the integrated platform that combines mobility demand with grid-friendly energy management. Whether it is the hotel's own electric vehicles that need charging or those of the guests, the system matches demand with the actual electricity supply and ensures fully charged batteries at the right time.

Energy

Using forecasts, control data and analysis, the system anticipates both energy demand and supply. The system dynamically controls whether charging happens quickly or slowly ahead of the time of departure. It also considers the option of providing control energy to the grid in order to relieve

both building connection and grid and to participate financially in the energy market.

Networked communication

The charging unit with all its ports is a communicative unit that can control and be controlled. The system integrates forecast charging power as well as current grid data into the property's energy management. As a result, the charging stations are part of the overall energy management of the building.

Opportunities for providers and users

The service allows both hotels and guests the opportunity to negotiate a charging plan, with financial incentives reflecting the speed and timing of charging while taking the building installation into account. The guest can enter their wishes via a tablet PC from the room or at the reception while the hotelier knows that their home connection is used gently.

Via a platform, electric mobility offerings such as charging or car and pedelec sharing can be managed and billed. The vision to offer economically viable mobility services that support electric mobility at hotels has thus been implemented and allows for the integration of new service concepts.

Illustration 6: Supporting electric mobility through smart and digital services



Source: Project DiTour-EE

 For further information:
www.ditour-ee.de

Consortium partners

Betterspace GmbH (Leader of the consortium),
Fraunhofer IEE, HKW-Elektronik GmbH



eJIT

JIT – Logistics system based on electromobility

The Challenge

HGVs burn large amounts of fossil fuels, even in short-haul operation. The objective is to electrify these heavy workers of just-in-time (JIT) logistics to reduce local fleet noise and emissions.

While this may sound simple it requires highly sophisticated sensors, control and communications technology as well as the integration of information from various data sources. The four project partners brought together experts from automotive and logistics industries to create a JIT system for electric HGVs by the end of 2018.

The approach

Two fully electric 40 ton tractors will be built and tested under real industry conditions at Saxon automotive industry sites Zwickau and Leipzig. The testing routes at the two sites pose different challenges for the vehicles: In Zwickau much of the test track is on major roads with compara-

tively high speeds of 60 to 80 km/h and also includes significant inclines. By contrast, in Leipzig, vehicles predominantly run within the city and on flat terrain.

The project partners develop performance and vehicle assistance systems for electric JIT haulage. The project aims for sustainability in logistics by avoiding emissions during the journey. The systems to be designed will optimise consumption but also the charging of batteries and the operation of vehicles in a three-shift pattern.

As a technology highlight the Leipzig project vehicle will not only be equipped with electric propulsion but also an assistance system for highly automated driving. This includes the installation of car2X technology at several traffic lights, that allows communication with the vehicles in the environment. In the end, both test tracks require intensive exchange of data between drive and control of the vehicle, the logistics system of the plant and general traffic. From this, the “eJIT logistics model” emerges.

Illustration 7: Design of the project vehicle with electric drive and driver assistance system



Target users and benefits

The addressees for the use of the control elements are cargo traffic in the automotive sector, JIT and Just-In-Sequence (JIS) transports and new interactive traffic concepts.

The quality of vehicle assistance systems will become more and more important as a factor in determining the competitiveness of JIT logistics providers. Hence, shippers and logistics companies will benefit along with other sites of the eJIT project partners.

Energy

During loading and unloading, the tractors are stationary. Those are ideal time intervals for charging their batteries. DC connections with an output of 150 kW enable fast energy supply for long distances in the project.

Networked communication

The planned performance and vehicle assistance system is designed as an interactive communications hub. It processes telematics, operations, production and vehicle data and derives commands for action.

Opportunities for providers and users

eJIT responds to changes in means of transport and local requirements for air pollution and noise pollution. Transit through cities and residential areas becomes cleaner and quieter, this significantly reduces the burden on local residents.



For further information:
www.e-jit.de

Consortium partners

RKW Sachsen Rationalisierungs- und Innovationszentrum e.V. (Leader of the consortium) als Träger des Netzwerks Automobilzulieferer Sachsen (AMZ), IAV GmbH, Porsche Leipzig GmbH, Schnellecke Logistics, Volkswagen Sachsen GmbH

eMobility-Scout



Integrated e-mobility platform for e-vehicle fleets with commercial vehicles and shared infrastructures

The Challenge

Electric mobility in the commercial sector must be profitable. It holds the potential for avoiding huge amounts of emissions and particulates. Using e-vehicles in commercial fleets requires the dynamic integration of vehicles and loading technology into fleet management planning. Booking of internal and external charging opportunities as well as networking of vehicles across sites needs to be captured in an ICT solution to optimise availability and utilisation of vehicles. Moreover, sustainable operation of fleets requires real-time integration into intelligent energy and traffic grids. Electric mobility becomes attractive to fleet operators once all those requirements are met. In progress since

January 2016, this project will present relevant results and conclusions at the end of 2018.

The approach

The integrated cloud-based solution eMobilityScout links users and infrastructure. Companies that connect to eMobilityScout via an “eFleetCockpit” can use it, for example, to optimize routes and rosters as well as the utilisation of the charging infrastructure. Thus, charging points can be used in a smart and simple way by their operator but also by other companies as well as the general public. The eMobilityScout is also intended to support fleet operators in expanding

Illustration 8: eMobility-Scout scenario: a cloud-based IT solution

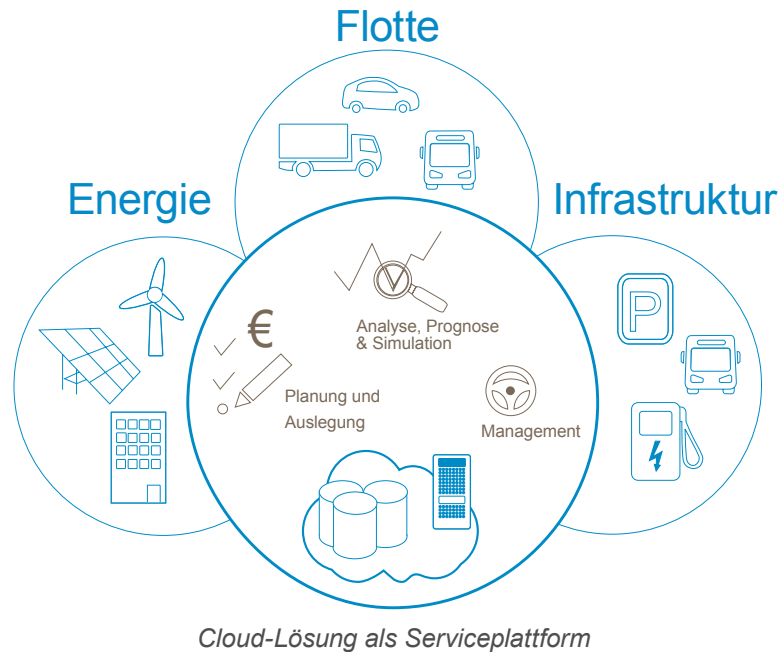

Source: Project eMobility-Scout

and converting their existing fleets into e-fleets by proposing fleet size and composition as well as locations for the charging infrastructure in its analysis, forecasting and simulation programs.

Target users and benefits

In a single step, both efficiency and sustainability of a commercial fleet are increased. The utilisation of infrastructure and capacity of all companies integrated into the network leads to new business models. Existing ICT components are integrated through open interfaces and thus retain their value. The more logistics companies, fleet operators and fleets join the solution, the more everyone benefits.

Energy

The interactive integration of the energy infrastructure optimises the utilisation of electricity from storage systems when charging vehicles. Within the management of charging processes, the performance of the fleet is the top priority.

Networked communication

An integration layer in the cloud application links to external systems via standardised interfaces. Data collected from such sources are used by the eMobility-Scout framework for interactive processes such as planning, booking and optimisation services.

Opportunities for providers and users

With this solution it becomes easier for fleet operators to meet CO₂ regulations. Operators electrify their fleets in manageable, safe steps while continuing operations, or build new fleets using the cloud solution.



For further information:
www.emobilityscout.de

Consortium partners

Carano Software Solutions GmbH (Leader of the consortium), BVG Berliner Verkehrsbetriebe, Fraunhofer-Institut für Arbeitswirtschaft und Organisation IAO, in-integrierte informationssysteme, TU Dresden

GridCON

GridCON (completed 12/2017)

Grid-Connected Agricultural Machine

The Challenge

Agriculture is particularly affected by the consequences of climate change. At the same time, it contributes to it. By using renewables as well as efficient methods and technologies the climate protection potential of agriculture can be exploited. As a significant contribution to exploiting this potential, Project GridCon developed and tested a fully electric drive for agricultural machinery using a direct cable connection to the grid and thus demonstrated an effective contribution to climate protection.

The approach

The project covered development, construction and demonstration of a cable-based fully electric agricultural machine (tractor) along with a Smart Grid infrastructure. The tractor is supplied through an electric cable that links it to the grid. The project included the design of a device that guides the cable towards the moving tractor in a suitable fashion while meeting relevant (safety) regulations. The demonstration was conducted with an electrified attachment that draws significantly more power than a conventional base tractor.

Illustration 9: Fully electrified agricultural holdings as prosumer in rural Smart Grids



Source: Project GridCON

Target users and benefits

Farmers see themselves as stewards of nature as well as the cultivated landscape. With GridCON they can fulfil this mission even better. An electric agricultural machine weighs less and thus contributes to a reduction of soil compaction. It allows a more precise and economical application of pesticides and fertilisers compared to conventional agricultural machines. Lower energy costs and more than a doubling of energy efficiency make the approach commercially attractive. The concept enables the buffering of regional excess electricity in the farm's battery storage. During load peaks, electricity is sold or used internally. In this way, farmers contribute to the stabilising of grids and open up new revenue sources for themselves.

Energy

The cable-based tractor was designed for high continuous power output. To complement this, a Smart Grid infrastructure for the electrical supply was developed that facilitates the local balance between energy generation from renewables, consumption by the tractor, and further stationary consumers. In the field the tractor is supplied with medium voltage DC current (> 6000 V) which is converted to 700 V DC for the on-board electrical system.

Networked communication

Through open interfaces the tractor can be flexibly integrated into communications and energy networks while maintaining the highest standard of data security.

Opportunities for providers and users

Compared to conventional drives, electric drives allow a more dynamic performance, higher power density and energy efficiency, an excellent controllability as well as a comfortable work environment and increased convenience of operation. If they are also combined with sensors and forecast systems then fields can be worked with high spatial precision, equipment can be utilised efficiently, and yields can be optimised. The GridCON approach also contributes to a cost reduction for the drives, advances independence from the oil price and decreases maintenance costs. Moreover, noise, emissions and hydraulic oil contamination of farmland as well as soil compaction can be reduced.



For further information:

www.gridcon-project.de

Consortium partners

John Deere GmbH & Co. KG (Leader of the consortium),
B.A.U.M Consult GmbH, TU Kaiserslautern

GridCon2

Cable-based mobile and autonomous machinery unit – development, construction and testing

The challenge

Agriculture wants to work its fields in an environmentally friendly, energy-efficient and cost-effective manner. Additionally, the use of fertilizers and pesticides as well as the dependency on fossil fuels prices should decrease. Furthermore, soil needs to be compacted less, and emissions must be avoided. GridCon2 enables sustainable field work through the electrification of agricultural machinery and the use of sustainable energy.

The approach

The GridCon2 project aims to lay the foundations for the electrification of other differently configurable agricultural machines. This includes a power distribution vehicle and a power supply module with a broadband communication infrastructure to control the highly automated and autonomous agricultural machinery units.

GridCON

Illustration 10: Cable-based mobile and autonomous machinery unit

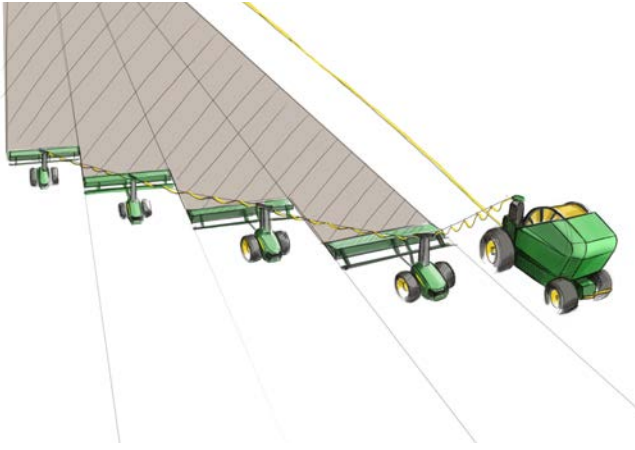

Source: Project GridCon2

An energy distribution vehicle receives electrical energy via a cable several kilometres long from a power supply module at the edge of the field and thus feeds additional agricultural machines in the field via another cable. The semi-stationary power supply module on the edge of the field can be connected to the grid and equipped with a large energy storage unit. It can be relocated easily in order to be used at different locations and can also serve as a buffer storage for volatile electricity generation from renewable energies.

Target audience and benefits

The solution serves farmers with large fields in close proximity to each other. Farmers benefit from substantial cost reductions through lower energy and operating costs as well as higher quality yields.

Energy

Due to the long feeder cable, only relatively few power connections are required for operation in order to enable the machines to work. During off-duty periods, the supply module's energy storage is used by the grid to store excess renewable energy and to feed it back at peak times, or the module is charged for the next operation. Predictive energy management provides control functions between all participating modules as well as the power supply.

Networked communication

A 3-D cable sensor measures the cable traction with high precision and regulates the cable-laying between between the different machines. This minimizes wear and repair costs for cables. The communication between all modules and the higher-level process control layer is transmitted via data cable integrated in the power cable.

Opportunity for providers and users

Dimensions, chassis and steering geometry of the machines are adapted to the respective requirements and thus offer high flexibility. The low weight of the electric-powered machines causes significantly less soil compaction, the high-precision control reduces the application of resources (fertilizer, pesticides) and the electric drives do not lose any hydraulic oils. Economically and ecologically sustainable farming thus becomes possible on a large scale. Utilities also benefit because the grid is protected by storage technology, while a significant expansion of the often weak grids in rural areas can be avoided.

Consortium partners

John Deere GmbH & Co. KG (Leader of the consortium),
B.A.U.M. Consult GmbH, Technische Universität
Kaiserslautern



Hub Chain

Mobility assurance when coupling on-demand and scheduled public transport through digital mobility services

The challenge

Electric, autonomous on-demand shuttles are designed to carry passengers along their travel chain, from a train station across the last mile to their destination or, from their starting point to a mobility hub. The service shall be easy to book and pay via app and shall be integrated into existing public transport offerings to allow everyone access to this integrated mobility service. By 2020, the research team will present a mobility platform that facilitates travel and commuting.

The approach

An ICT platform will link on-demand services to bus routes of scheduled public transport to form sensible travel chains, and will also guarantee mobility in rural areas. The

on-demand mobility offering will manage the available number of shuttles so that even at peak times there will be sufficient capacity in order for every passenger to make their connection. A guaranteed connection at hubs (such as train stations) is particularly important to customers.

Target users and benefits

The platform benefits both public transport providers and rural residents. Public transport operators can offer mobility services in sparsely populated areas where e.g. the use of scheduled buses would otherwise be unprofitable. Moreover, mobility providers can increase their load factor. Customers in turn can reduce their mobility costs and travel time once they forgo their own car and have a way to travel home through autonomous shuttles at the final stop of buses and trains.

Illustration 11: Overview graphic of the interlocking of on-demand and intermittent services

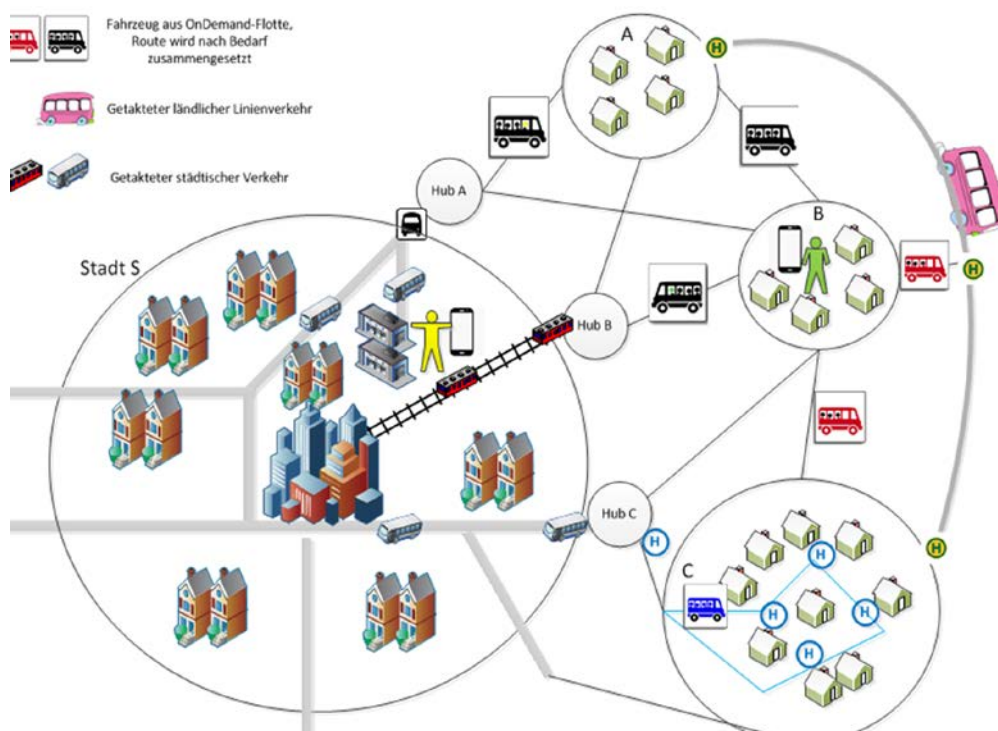

Energy

The autonomous electric shuttle buses save energy in several ways. Since they use electricity from renewables to charge, the carbon footprint of passengers and the burden on communities and target cities can decrease significantly. By avoiding many individual journeys, the energy saving effect increases further.

Networked communication

An autonomous minibus practically works like any call-a-bus service. Therefore, the distribution concept and customer platforms will merge to form a new mobility concept for connecting local hubs with scheduled services. The inclusion of data on infrastructure and traffic telematics goes without saying.

Opportunities for providers and users

Traffic in municipalities is reduced and roads are relieved. Mobility is becoming more economical for passengers and operators.

An integrated forecasting tool makes anticipative decisions in order to optimise route planning while including on-demand offers so that travellers or commuters reach their destination more quickly. This results in dynamic timetables which enable intermodal, digitised and highly flexible public transport. As a result, public transport becomes attractive again, especially in rural areas, while the reduction in originating traffic relieves the surrounding cities.



For further information:

www.hubchain.de

Consortium partners

Stadtwerke Osnabrück (Leader of the consortium), DLR – Institut für Verkehrssystemtechnik, HaCon Ingenieurgesellschaft mbH, Institut für Klimaschutz, Energie und Mobilität Recht, Ökonomie und Politik e.V. (IKEM), Innovationszentrum für Mobilität und gesellschaftlichen Wandel (InnoZ) GmbH, Kompetenzzentrum ländliche Mobilität (KOMOB) Institut in der Forschungs-GmbH Wismar

iHub



Intelligent IT-supported platform for electromobile, sustainable and efficient infrastructure and fleet management of logistics hubs

The Challenge

In general cargo logistics, a range of factors determine route planning and the choice of vehicle, including the classification of the tour, the availability of the vehicle and the optimisation of tours. In cases where there are electric vehicles in the fleet, battery status and hence range are additional parameters that need to be taken into account. The use of electric HGVs should be used whenever they are able to deliver as reliably and punctually as diesel vehicles. The system is to be ready for operation by the end of 2018.

The approach

The iHub ICT platform controls the deployment of electric HGVs up to 18 tons in mixed fleets for general cargo logistics. This is supported by predictive battery utilisation management, dynamic tour planning that optimises state of charge and replacement tours as well as by integrated energy management that controls cost-optimised battery charging.

In practice, the information hub integrates data from the management of buildings, energy, charging points and

Illustration 12: Project iHub – Conception

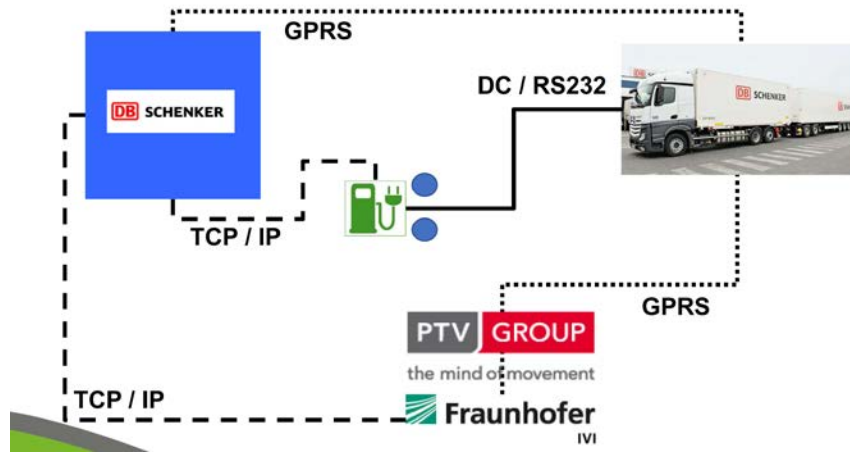

Source: Project iHub

logistics, and controls the resource- and cost-optimised use of the electric HGVs. iHub features all relevant interfaces and communicates with data providers and recipients that optimise the logistics. These also include renewable energy sources, large battery storage systems and the electric HGVs themselves. The radio-based data channel provides access to telematics that facilitates real-time processing of large data volumes for battery energy and tour management.

Target users and benefits

Haulage companies and fleet operators are faced with ever stricter emissions regulations and with fierce price competition. Through the intelligent and economic integration of electric HGVs, renewables and battery storage models they secure long-term access to inner cities and are able to offer cost-effective, post-fossil, emission-free logistic services. Therefore, electric vehicles in a mixed fleet provide economic benefits in two respects.

Energy

To maximize the sustainability of the fleet, electricity from large battery storage systems and renewables is preferred. Because general cargo traffic at the local level covers approx. 86 percent of all deliveries and collections within a 17 km radius, it is very feasible to set up the charging infrastructure at the cargo distribution centres or hubs. Some of the required energy can be generated at those sites using solar or wind power. Additional energy requirements are

coordinated with building energy and network management through the Smart Grid in order to avoid peak loads.

Networked communication

Standardised interfaces between systems and towards vehicles enable collection, processing and transfer of all relevant data required for iHub use cases.

Opportunities for providers and users

iHub allows logistics service providers a smooth transition to an environmentally friendly vehicle fleet. Through the portal, fleet operators can convert their fleets gradually and with manageable financial implications, they can remain operational, and they can purchase regionally generated energy. Such progress boosts the local economy and its returns.



For further information:
www.ihub-projekt.de

Consortium partners

DB Schenker Deutschland AG (Leader of the consortium), EMO Berliner Agentur für Elektromobilität, Institut für postfossile Logistik an der Hochschule Bochum, FRAMO GmbH, Fraunhofer Institut für Verkehrs- und Infrastruktursysteme, PTV Planung Transport Verkehr AG

iMove

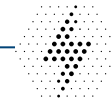

iMOVE

ICT solution for intermodal mobility services and integrated control of electrically operated fleets, taking into account forecast network and transport capacity utilisation

The challenge

If cities do not significantly reduce their particulate emissions, they face severe penalties and traffic collapse due to local driving bans. Especially in cities with high emission levels, emission-free mobility through the electrification of means of transport is of great importance. Intelligent charging management is particularly necessary with an increasing number of e-vehicles in order to avoid additional loads in the power grid and, if necessary, to enable relief. Within the framework of the iMOVE project, a platform is to be created between 2017 and 2019 to provide intermodal mobility services and optimally control electrically powered fleets, taking into account predicted utilisation of networks and means of transport.

The approach

The iMove project meets this challenge by developing an intermodal ICT solution in Stuttgart that enables integrated processing of all relevant data from the energy supply, charging infrastructure and transport system. A flexible system platform will collect data from traffic, charging and energy systems and determine an optimal traffic flow and energy consumption. Bottlenecks are to be identified and avoided preventively with demand, condition and capacity utilisation forecasts. The comprehensive implementation of intelligent incentive and control options for integrated route and charge management for electric fleets (e.g. special e-mobility tariffs) support the optimal use of resources.

Illustration 13: Example of possible Use Cases (Use Case for bottleneck relief) in the iMove project

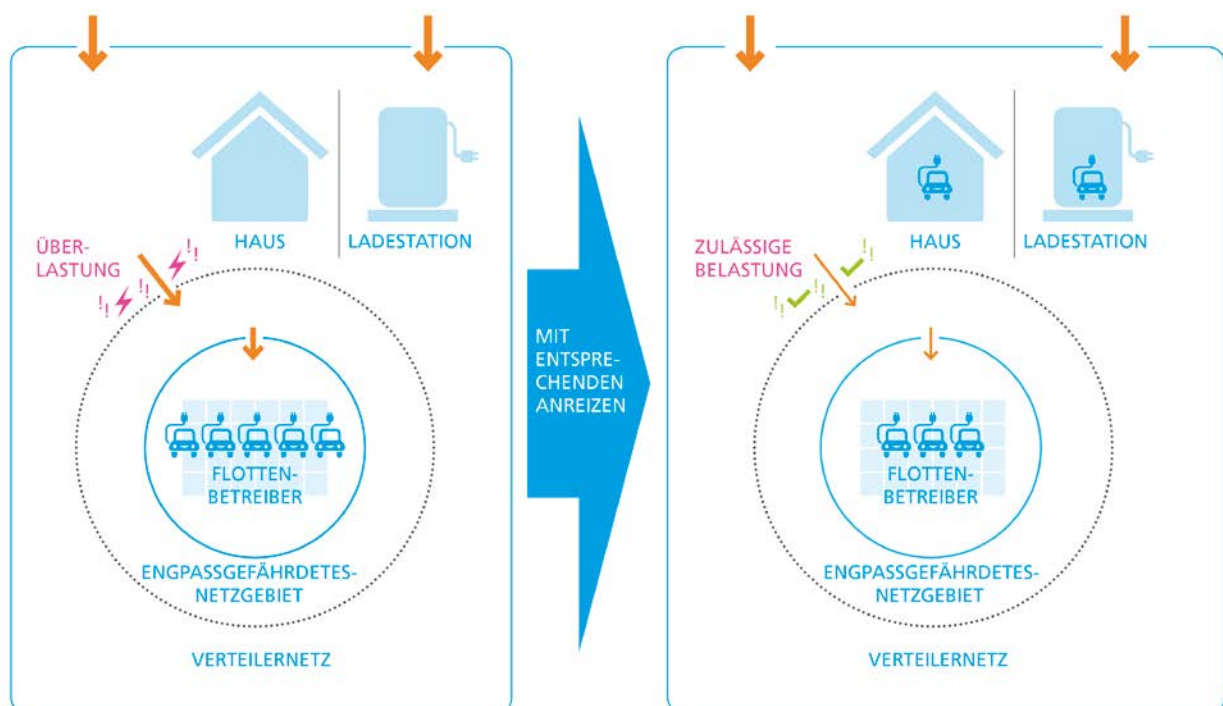

Target users and benefits

iMOVE offers energy and mobility providers and their customers as well as traffic management systems the opportunity to become part of the platform. The citizens of the city benefit most, because people and goods can reach their destinations more quickly with less traffic and emissions. At mobility hubs, the transition from one system to another is seamless, e.g. from public transport to car sharing. A new business area with billable services is opening up for providers.

Energy

Energy preferably comes from decentralised, regenerative generators. The network controller integrates storage systems and electricity providers into decentralised power plants. Electric cars as energy storage units also play a part in this.

Together, all these help to minimise energy imports and ensure effective mobility. Traffic and energy must thus be seen as an integrated system within a smart city solution.

Networked communication

The cloud-based information platform includes generic interfaces to exchange data between data sources and users.

The transport system, electric vehicle fleet, and energy system are both data providers and users. Learning systems can then take on forecasting of demand, status and load as well as bottleneck identification and optimisation of electric vehicle fleet management. When it comes to billing and booking of vehicles and electricity, the system can integrate appropriate services anytime.

Opportunities for providers and users

Descriptive and predictive data analysis and networked data validation and processing enable new business models for smart city solutions. Cities can design routes that take into account congestion and particulate matter and thus control traffic and energy as an integrated system.



For further information:
www.imove-projekt.de

Consortium partners

Hubject (Leader of the consortium), TomTom Development Germany, Stadtwerke Stuttgart, SOPTIM, RWTH Aachen, OM – Lehrstuhl für Operations Management, RWTH Aachen, OR – Lehrstuhl für Operations Research, RWTH Aachen, ISB – Institut für Stadtbauwesen und Stadtverkehr

lokSMART Jetzt! 2

Electric mobility in the local smart grid

The Challenge

The objective is for commercially used electric vehicles to maximise the proportion of electricity from renewables that they consume. The associated energy management shall control a local Smart Grid that links energy producers, storage systems and electric vehicles with a view to optimising route and energy planning as well as grid stability. Guaranteeing the full mobility of the fleets has top priority in this context.

The approach

lokSMART Jetzt! 2 develops solutions for the local use of combined heat and power plants and regenerative sources in combination with electric storage tanks and electric vehicles. As a control system, lokSMART Jetzt! 2 optimises local Smart Grids that coordinate timeshifted charging and discharging of stationary batteries and electric vehicles with renewable, locally generated energy. To achieve this, vehicles are equipped with bidirectional DC/DC charging technology (G2V and V2G), which means they can take electricity from the grid and feed it back. Each charging point features 60 kWh of buffer storage, equivalent to the



Illustration 14: Coordination of decentrally generated energy from photovoltaic and combined heat and power plants for the charging of e-vehicles and stationary e-buffer storage in the lokSMART Jetzt! 2 project

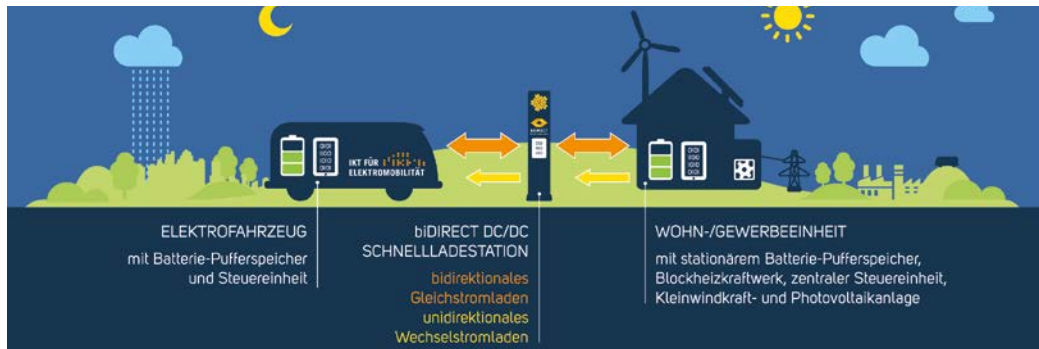

Source: Project lokSMART Jetzt! 2

capacity of mobile storage in the eSprinter vehicles. The system receives information about planned routes of entire fleets as well as short notice individual journeys, compares the likely energy requirement with the state of charge of the vehicle batteries, and draws on the energy stores of the network for rapid charging. Tariffs based on overall balances calculate for the various sites of the system in the project area the energy that was generated, stored, and provided. The complete system is tested in three different field test modules: in the branch logistics of a medium-sized bakery, in the commercial car and delivery traffic of a planning office and in an event catering company.

Target users and benefits

The energy requirements of fleets for branch network logistics are met using electric buffer stores at fixed sites or from sustainable electricity sources directly via the grid. The project addresses enterprises with at least partially plannable routes in their fleets as well as private households. With these two target groups the project is potentially of interest to millions of vehicles and users. With its battery, each electric car contributes to stabilising the grid and is financially compensated for this service. Local energy suppliers also benefit from the project since the Smart Grid takes care of the tariffs of various sites in their balancing groups.

Energy

Energy is generated by regional, sustainable plants. It can be consumed immediately or can be buffered in vehicles and charging stations with combined buffer storage and

then retrieved as and when it is needed. This allows a high on-site consumption of renewable energy, relieves the grid during peak loads and significantly minimises the cost of managing the grid.

Networked communication

Through a web platform the Smart Grid communicates with the linked components and the electricity grid. It controls energy flows and implements the mobility for the attached vehicles.

Opportunities for providers and users

With its control capabilities the Smart Grid is able to compensate fluctuations in electricity supply associated with the increasing number of renewable energy sources in the grid. The cost of managing the grid as well as energy consumption are reduced, and the utilisation of energy sources goes up. Operators of energy production plants, charging infrastructure and vehicle fleets become partners in a win-win constellation.



For further information:
www.loksmart.de

Consortium partners

Planungsbüro Koenzen (Leader of the consortium), Hochschule Osnabrück, Ihr Bäcker Schüren, SenerTec Center Sachsen, Stadtwerke Hilden, Villa Media Gastronomie, Westsächsische Hochschule Zwickau

MENDEL



Minimal load on electrical networks due to charging processes of electric buses

Illustration 15: Systems approach in the project MENDEL: Integration of the previously separately considered domains Intelligent Traffic Systems (ITS) and Smart Grid

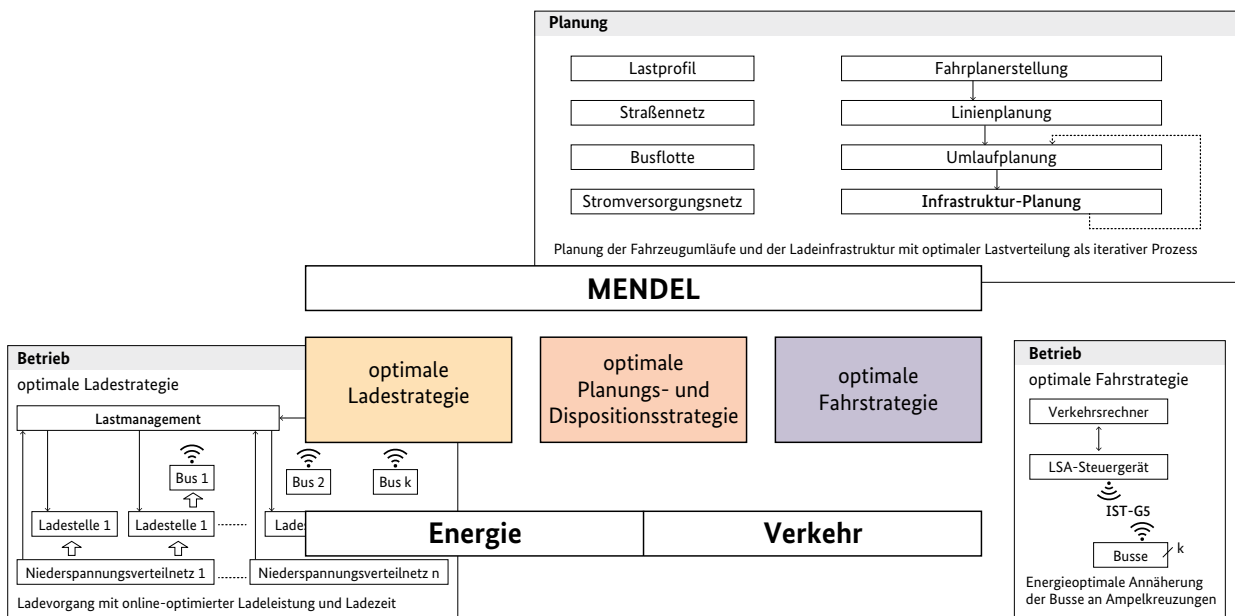

Source: Project MENDEL

The Challenge

The title of the project describes the challenge: “Minimale Belastung Elektrischer Netze Durch Ladevorgänge von Elektrobussen“ – Minimal load on electric grids from the charging of electric busses.

The investment in charging infrastructure should be kept as low as possible. Additional expensive transformers in the low voltage distribution grid should be avoided. Moreover, the focus is to avoid consumption peaks. Since the quarter of an hour per year with the highest electricity consumption determines the consumption-independent demand rate (electricity price) for the whole year. The peak consumption and thus the demand rate should be kept as low as possible for the entire fleet by means of intelligent charging technology and strategies.

The approach

MENDEL optimises the grid integration of regular scheduled buses through the Smart Grid as well as route design, charging strategy and driving behaviour. Special programs and algorithms plan the charging infrastructure and calculate the optimized load and charging management in real time.

Before the buses set off, the roster and the optimum positioning of charging points is calculated to minimise the charging need of the buses. In case a bus links up with a station at a favourable time it draws electricity directly from the grid. Depending on the build-up of the infrastructure, inductive charging can be considered, too. Integration of the buses into the traffic control network allows green traffic lights for them as far as possible. The time and energy savings that result from the lack of braking and accelerating are significant and are yet another contribution towards keeping the consumption-independent capacity charge as low as possible, i.e. to put as little load onto the grid as possible. Results will be available by end of 2018.

Target users and benefits

Operators of bus fleets, delivery traffic for branch networks, and other services with recurring routes can significantly reduce their overall fleet costs.

Energy

Real-time communication for calculating the optimum storage and consumption strategy allows the operation of additional electric buses in the existing low voltage grid.

Networked communication

The integrative approach makes use of manufacturer-independent standards such as OCIT (Open Communication Interface for Road Traffic Control Systems) and the VDV standards (Verband deutscher Verkehrsunternehmen) as well as VDE guidelines (Verband Elektrotechnik Elektronik Informationstechnik e.V.). Traffic planning is guided by the regulation for traffic signals (RiLSA). Thus, interfaces are defined between all actors such as vehicles, intelligent traffic systems, Smart Grid and public transport driver assistance. The interfaces support a bidirectional data transfer.

Opportunities for providers and users

The cooperative cluster of systems formed by the operations control system (ITCS – Intermodal Transport Control System), traffic management and traffic light control system provides new growth opportunities for the grid operator as well as for the operation of public transport.



For further information:
www.mendel-projekt.de

Consortium partners

INIT GmbH (Leader of the consortium), AVT STOYE GmbH, Institut für Verkehrssystemtechnik des Deutsches Zentrum für Luft- und Raumfahrt e.V. (DLR), Fraunhofer Institut für Materialfluss und Logistik (IML), GEVAS Software Systementwicklung und Verkehrsinformatik GmbH, Institut für Automation und Kommunikation e.V. Magdeburg (IFAK)

OVAL



Ad hoc charging and payment

The Challenge

For long distances, publicly accessible charging points are available for drivers of electric vehicles. In order to obtain electricity at those points, drivers usually need to enter a contract with an electricity supplier or operator and need to carry an RFID card. However, EU law demands in directive 2014/94/EU paragraph 4 subparagraph 9 that it must be possible to charge ad-hoc at publicly accessible charging points without having previously entered into a contract. The OVAL project has set itself the goal of carrying out fundamental studies and implementing and testing suitable prototypical solutions by the end of 2019.

The approach

The project starts with an analysis of the existing charging station billing systems and an evaluation of the options to add payment options without a traction current contract. A study summarizes the results and makes recommendations for their implementation. Based on this, pilot ad-hoc payment options are implemented to test user acceptance, market relevance and technical feasibility in practice and to find the best solutions. Since operating costs are to remain low, paying with cash is not a relevant option from the project's point of view. Instead, modern, ICT-based payment systems are preferred. At the end of the project, systems should be installed at frequented loading locations that offer barrier-free ad-hoc loading as an additional option.

Target users and benefits

Accessibility when charging the electric car is an important aspect that positively influences user acceptance. However, the decisive factor is how customer-friendly the communication between the e-car driver and the system is in ad hoc loading and payment. Particular attention will therefore be paid to this aspect in the pilot phase of the project.

Energy

The charging energy provided is billed according to the current calibration law requirements. Therefore, the charging energy must be billed according to the energy unit, i.e. kWh. To meet these requirements, the consortium leader will develop a storage and display module (SAM) and a DC electricity meter as part of the OVAL project. The SAM unit must be used together with an electricity meter that meets the requirements of the calibration law or the European Measuring Instruments Directive (MID). In order to implement the ad-hoc payment procedures for the DC charging stations in addition to those for AC charging stations, a DC electricity meter is being developed and integrated into the charging station prototypes.

Networked communication

The project assumes cashless payment via centralised services. Roaming is already state-of-the-art in the EU and allows borderless mobility if communication networks of operators and billing service providers are synchronised. The project phase will show how the communication of the charging infrastructure can be implemented in the most customer-friendly way.

Opportunities for providers and users

The option of loading and paying without prior notice will significantly increase the number of loads to be billed. This opens up new business opportunities for operators and payment services. EU-wide secured and customer-friendly implemented accessibility for payment rounds off the established roaming concept. This makes electric mobility even more attractive for users because they can now spontaneously travel nationwide or even internationally with their electric vehicle, for example.

Consortium partners

EBG compleo GmbH (Leader of the consortium), VDE Verband der Elektrotechnik Elektronik Informationstechnik e.V.

Illustration 16: The OVAL project analyses and evaluates the technical, economic and legal aspects of how ad hoc charging and payment can be realized

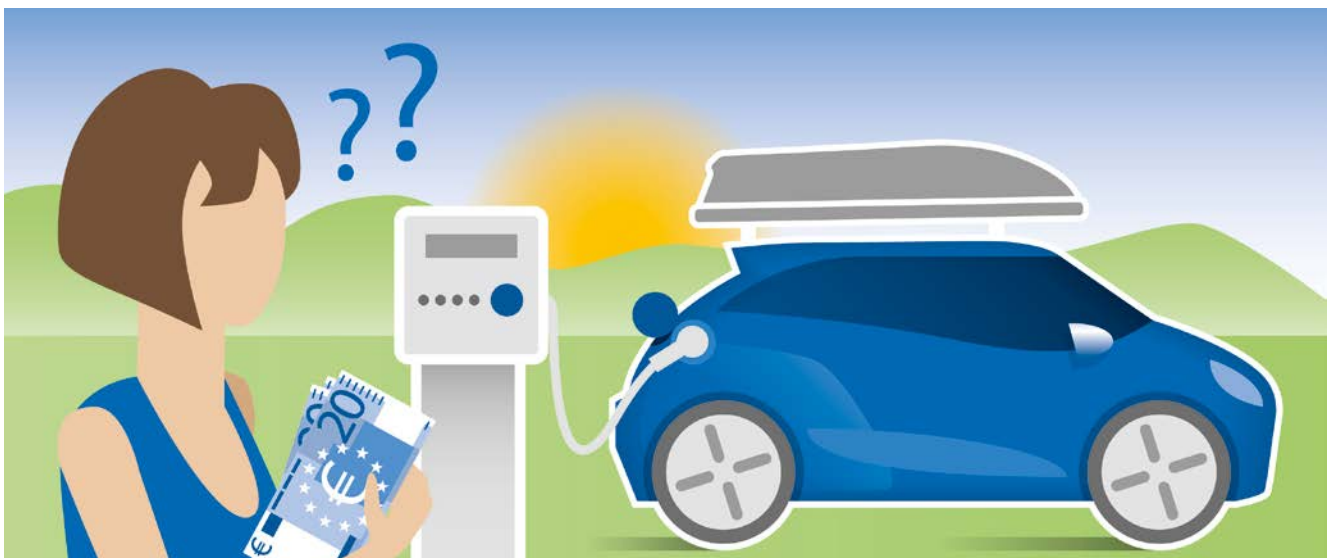



PostBot-E

Automated delivery and disposal services for urban districts by autonomous electric vehicles

The challenge

A growing number of parcels, congestion, and a high rate of undeliverable packages are increasingly causing problems for courier, express and parcel services (CEP) and inner-city traffic. PostBot-E promises to mitigate the problem and to reduce the impact of traffic and pollution on urban areas.

The approach

Autonomous electric delivery vehicles take over the supply for districts and optimize the logistics chain on the “last mile”. They deliver to mechatronic parcel boxes on buildings where packages are handed over fully automatically, and where empties or returns are collected for the journey back to the depot.

Target group and benefits

CEP service providers, disposal companies and local haulage firms benefit as operators of such neighbourhood fleets. Their delivery rate increases, because the nimble vehicles are not stuck in traffic and drive directly to the parcel boxes, regardless of a person being on-site or not. Thanks to the near-silent electric drives, the vehicles can make many trips even at night, and can use low-traffic times to complete additional journeys. Local retailers can also use this delivery service to develop new sales channels. Thinking further, the system may also be used in internal logistics chains.

Energy

The vehicles inductively and automatically charge their batteries at the parcel boxes while packages and returns are being unloaded and collected fully automatically. This way, the vehicles are constantly refreshing their range and can be in operation permanently.

Networked communication

Robust localization and navigation algorithms shall guide the vehicles to their destination safely, even in poor visibility. The self-navigating fleet receives its control data from the environment via video and laser sensors and also via a 3D map and the European Galileo satellite navigation system. For emergencies, a control center is available which intervenes should a vehicle no longer navigate independently. Route and order management are handled by the automated fleet management that works both centrally and locally. The integrated interface informs the user as soon as their package has been deposited at the parcel box.

Opportunities for providers and users

Hybrid fleet management that allows switching between automatic operation and control center intervention is a huge advantage for productivity. The fleet can thus maximise productivity due to less downtime and few idle times, and the possibility of carrying several parcels per vehicle and collecting returns or empty containers on the way back to the depot. The delivery rate can be increased from the current 65% up to 100%. Flexible transfer and recycling points allow high coverage of the districts without relying on depots.



For further information:
www.mendel-projekt.de

Consortium partners

SEW-EURODRIVE GmbH & Co. KG (Leader of the consortium), Forschungszentrum Informatik (FZI), Institut für Fördertechnik und Logistiksysteme (IFL), Leuze electronic GmbH & Co. KG, Transport Betz GmbH & Co. Speditionen KG

Illustration 17: Autonomous, electrically driven delivery vehicles take over the delivery traffic to the urban districts



Source: [bogevischs buero](https://www.bogevischs-buero.com)

RouteCharge



RouteCharge

Battery exchange system for the development of medium distances in the branch supply with electric commercial vehicles

The Challenge

Until now, electric commercial vehicles (e-HGV) have only been used as inner-city distribution vehicles with low touring variance. In the “RouteCharge” project, branch supply of up to 300 km are to be implemented for the first time. This can significantly increase the line performance of the vehicles, which has a positive effect on specific vehicle costs

(e.g. energy, service and maintenance costs). In order to save time for recharging the batteries, battery change stations are desirable instead of permanently installed onboard batteries, because fleet operators want to work with the same freedom of disposition and flexibility that they are familiar with from diesel vehicles. The results are to be made available to freight forwarders by spring 2020.

The approach

Battery replacement stations for the commercial electric vehicles are being built along a main freight traffic axis at intervals of approximately 150 km. The batteries used here bring double benefits (dual use) and double cash revenue. On the one hand, they serve as traction batteries for the vehicles and generate yields there. On the other hand, their capacity is available bidirectionally for grid-side control powers (regenerative power supply), while they are stored in the exchange stations. Changing batteries without waiting times is a top priority, because time is money in freight transport. Fleet scheduling therefore controls all connected systems such as charging processes and the grid integration of the battery stations. Priority is given to the storage of sustainably generated energy.

Target users and benefits

Three-shift fleets, medium-distance transports, branch supply and service providers for freight transports benefit from RouteCharge. They reduce their operating costs through lower operating costs and the second use of the battery change stations for control energy outputs. The

standardization of the battery systems allows their combination to many target systems. This also reduces costs. All these advantages together significantly improve the total cost of ownership (TCO) of e-HGV compared to other drive technologies.

Energy

The sustainability goal of the project is achieved through the optimal use of renewable energies. Intelligent management of energy and storage systems makes the best possible use of the fluctuating electricity supply from renewable energies and at the same time stabilises the electricity grid. This makes vehicle operation as CO₂-neutral as possible and keeps energy costs to a minimum.

Networked communication

A central communication platform takes over control. The platform has interfaces to integrated energy systems (IES), sustainable energy sources, large battery storage, DC rapid charge technology, buildings, battery management and vehicles.

Illustration 18: Topographic route depiction

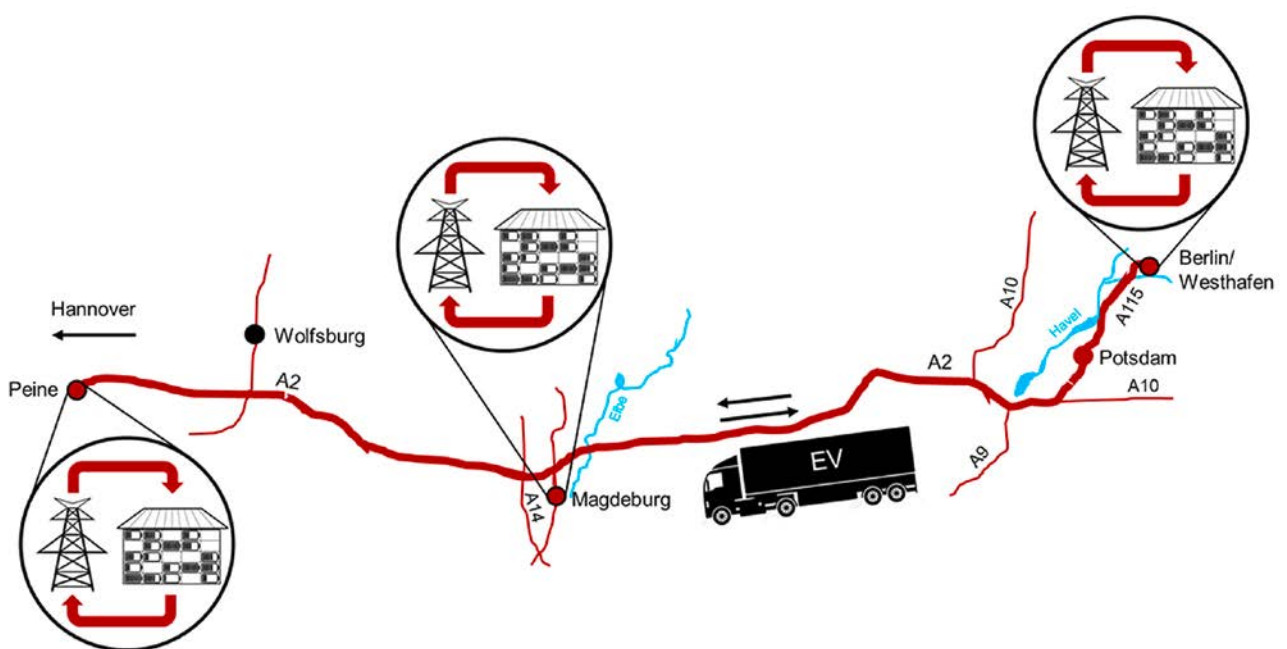

Opportunities for providers and users

The battery exchange system ensures long vehicle ranges for freight transport without loss of time. The operating costs are unrivalled low and this with a maximum of environmentally friendly energy used. Forward-looking, commercial e-vehicles guarantee delivery traffic in cities with environmental zones almost at any time, because they are not only emission-free, but also quiet. The battery change stations immediately generate revenue from the operating reserve for the power grid.

Consortium partners

MC Management GmbH (Leader of the consortium), Fraunhofer Institut für Produktionsanlagen und Konstruktionstechnik IPK, TU Berlin: Fachgebiet Logistik und DAI-Labor, WEMAG AG

SADA – Smart Adaptive Data Aggregation (completed 04/2018)



SADA vernetzt Sensordaten modular und adaptiv

The Challenge

In vehicles as well as in traffic management and infrastructure huge amounts of data from sensors are generated. Some systems expose their data on a Vehicle-to-vehicle or vehicle-to-infrastructure (car2X) interface, others do not. As a result, an unnecessarily large number of sensors is operated, and data are sometimes collected multiple times, while data is missing in other places. The SADA project (Smart Adaptive Data Aggregation) had as its objective to bring together traffic data from mobile and stationary sources in one backend, to add value to it, and to use it for mobility control. Traffic flows, infrastructure and vehicle utilisation can be optimised in order to reduce emissions and to increase efficiency, safety and comfort in traffic. In spring 2018, an operational demonstrator was presented.

The approach

SADA developed a system that networks the data available in the car, the data of the stationary sensor infrastructure, but also the data from sensors brought along, e.g. from smartphones, and then links them intelligently and flexibly. Capturing the traffic situation using mobile and stationary sensors and aggregating all this data (data fusion) allows the use of such data in arbitrary applications. The data platform SADA uses open source middleware to bring together raw data, context information and aggregated data and provides these to external systems. The practical dem-

onstrator of this project will be an application where multiple vehicles cooperate to spot parking spaces and assist with parking.

Target users and benefits

Vehicle manufacturers and developer of traffic and mobility services get access to a technology foundation that brings together, condenses and offers with a standardised description all the information that is relevant for a variety of traffic actors (including infrastructure services). Service providers and manufacturers can focus on the optimisation of their products and applications and thus roll out new solutions much faster and with more flexibility. Overall, many sensors become redundant, and the reuse of data can lead to better functionality.

Energy

Applications that process relevant data on energy supply, traffic conditions, routes and vehicles from the SADA platform are able to optimise the energy consumption of vehicles and, for electric vehicles, can control the charging strategy to optimise grid and cost impact.

Illustration 19: Representation of the various sensor data whose combination is being tested in SADA

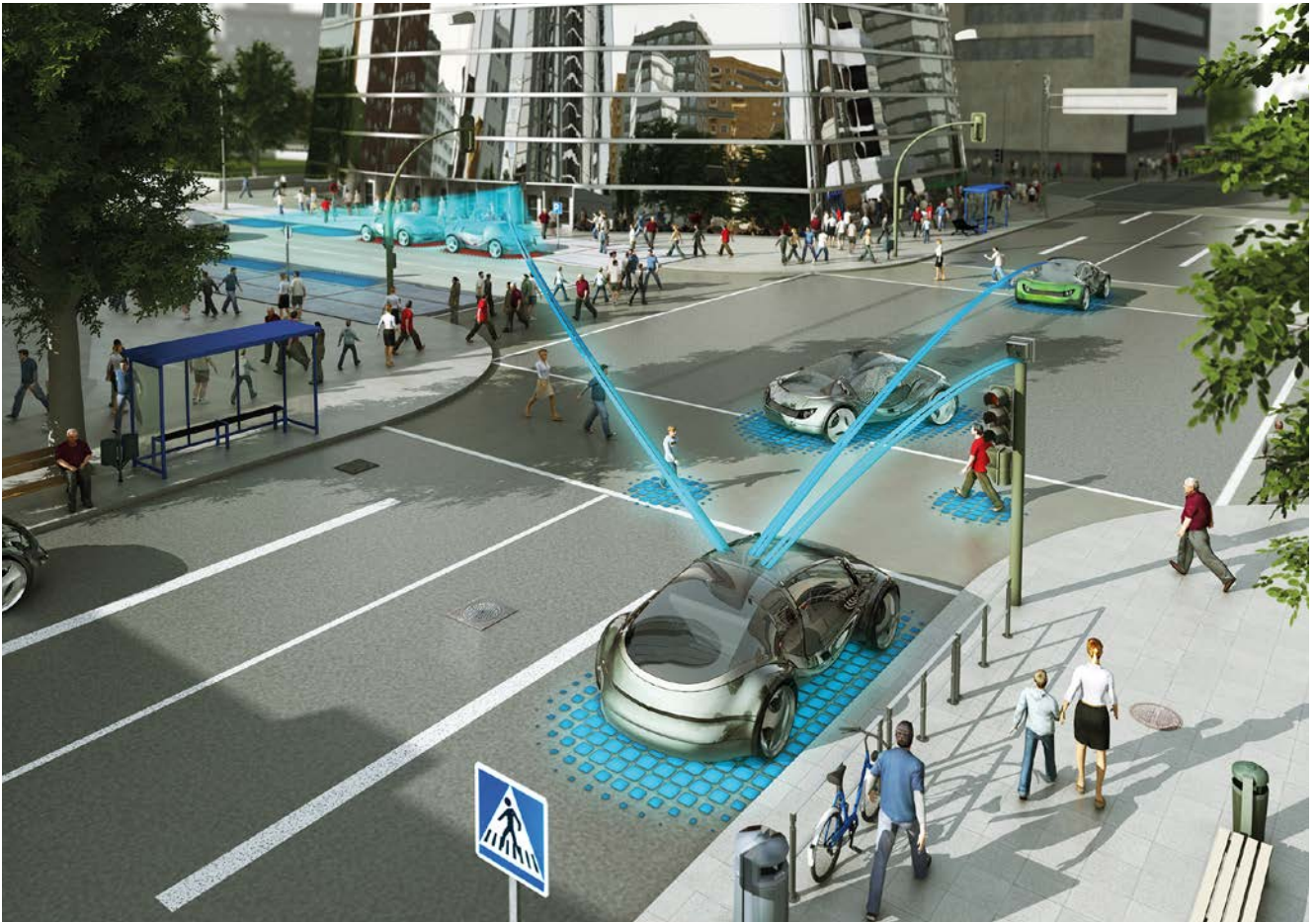

Source: Project SADA

Networked communication

The fusion of all data from environment (traffic), infrastructure (e.g. the electric grid) and car (e.g. environment detection) requires broadband communication within the vehicle (in car) as well as beyond the vehicle (car2X). Working out the appropriate network topology is one of the project tasks.

Opportunities for providers and users

SADA provides a holistic data foundation for individual Smart Car, Smart Traffic and Smart Grid applications that can be developed independent of the sensors. The project allows providers of autonomous driving approaches rapid, cost-effective and flexible entry into this market.



For further information:

www.projekt-sada.de

Consortium partners

Siemens AG (Leader of the consortium), ALL4IP TECHNOLOGIES GmbH & Co. KG, BASELABS GmbH, Deutsches Forschungszentrum für Künstliche Intelligenz gGmbH (DFKI GmbH), fortiss GmbH, NXP Semiconductors Germany GmbH

Smart Distribution Logistik

Adaptive system platform for delivery services

The Challenge

The logistics of media, such as newspapers, magazines and books, from their printing to the reader is changing as the industry expands its offering with complementary services such as delivery of daily newspapers, advertising materials and leaflets, mail delivery and mail collection. An intelligent system solution should reduce the total cost of owner-

ship of the vehicles used and especially the electric vehicles, so that they are economical from the first year of use. Beneficiaries should later be media and pharmaceutical logistics as well as other logistical scenarios. The project started in May 2017 and will present its results in April 2020.

Illustration 20: Illustration of the planned innovative system approach of Smart Distribution Logistik

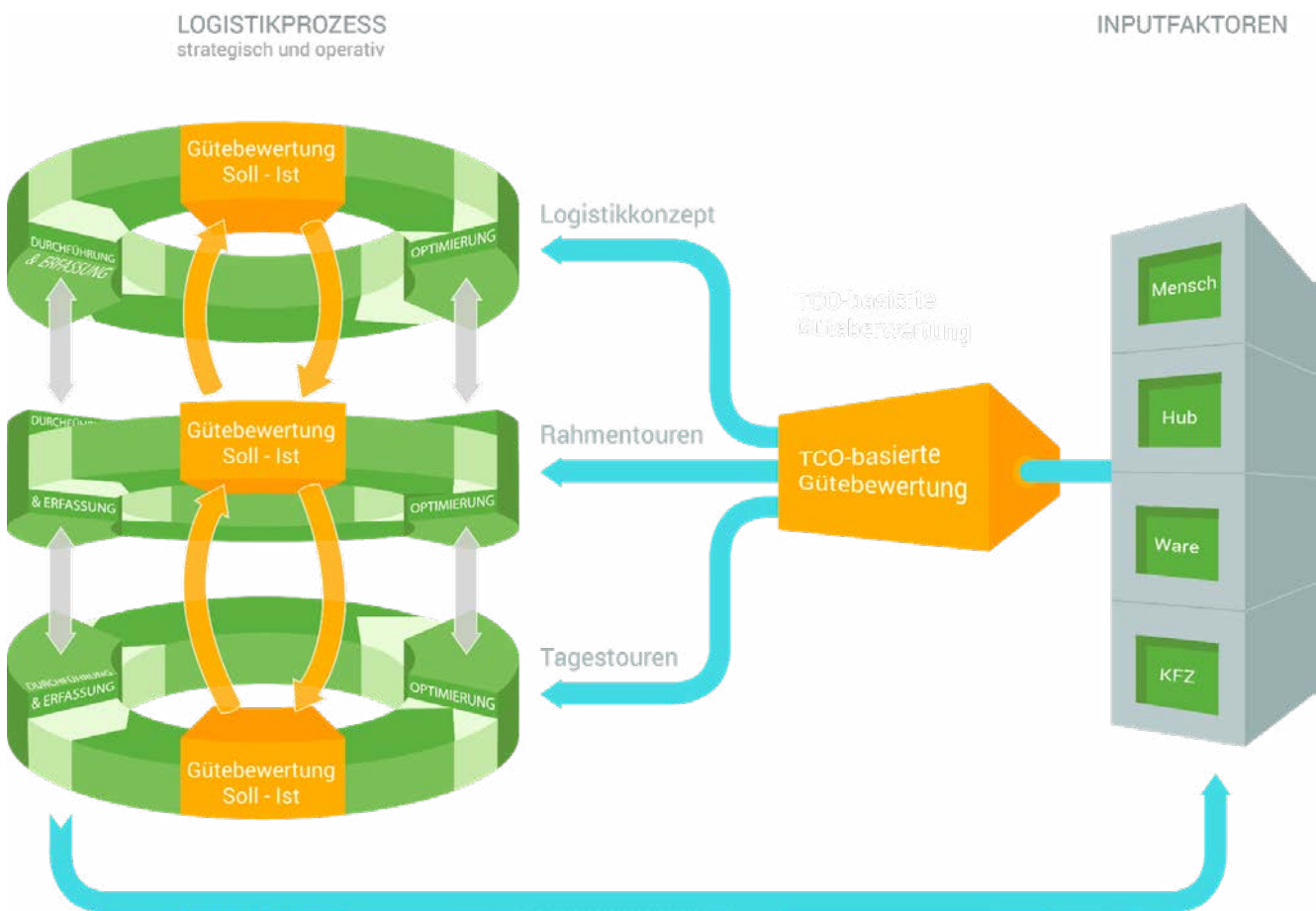

The approach

A dynamic planning and control platform will regulate the logistics chain and the use of the e-vehicles and optimise their battery charge. The required efficiency is to be achieved by means of an interlinked optimisation system at various levels and by means of multiple-use models of e-vehicles via truck and cargo sharing from 40-ton trucks to load pedelecs. This allows higher mileage per vehicle to be achieved. To cope with this complexity, optimization solutions are first developed for day tours, then for frame tours and then for the logistics concept with mobile distribution centers (hubs). The 6-month field test at the end of the project shows the performance of the system.

Target users and benefits

The platform will be available to media and pharmaceutical logistics and will also be used in other logistics scenarios. Their customers are to successfully integrate electromobility into their mixed fleets from the very first kilometre and reduce the costs of e-vehicles.

Energy

Within the scope of the project, cost-optimised vehicle charging is understood as the intelligent integration of fleet charging concepts into building energy management.

Networked communication

The self-scaling and dynamic system will later calculate instructions for action later to the minute from an experience-based optimization feedback and communicate them to the system participants. These feedback algorithms are being further developed in the project.

Opportunities for providers and users

Media logistics is one of the largest logistics sectors in Germany. In connection with the major changes taking place in the technological and social environment, there is a great opportunity to occupy suitable operating niches with electric vehicles in order to exploit both financial and CO₂ savings potentials. This will measurably accelerate the implementation of electromobility for the industry and other logistics branches.



For further information:
www.sdl-projekt.de

Consortium partners

DAKO GmbH (Konsortialführung), EPSa Elektronik & Präzisionsbau Saalfeld GmbH, Friedrich-Schiller-Universität Jena, Fachhochschule Erfurt, eLOG Systembetrieb GmbH, Sächsische Zeitung GmbH, LVZ Logistik GmbH

sMobilityCOM



Development of an integrated, predictive charging and deployment management for e-mobility-based services

The Challenge

Mobile care services are highly focussed on economic viability and acquire vehicles according to TCO (total cost of ownership) considerations. The objective is to turn this industry into an early adopter for electric cars. The challenge is to reduce operational and energy costs far enough

such that the small electric cars are already economically viable with a total annual mileage of 15.000 km (approx. 9400 miles). The electrification of pilot care service fleets already happens during the course of the project.

Illustration 21: Integration of the infrastructure components relevant to mobility into the energy grid and into the Energy management of the building and charging management through integration into a comprehensive IT-based deployment management of service provision

Projektidee

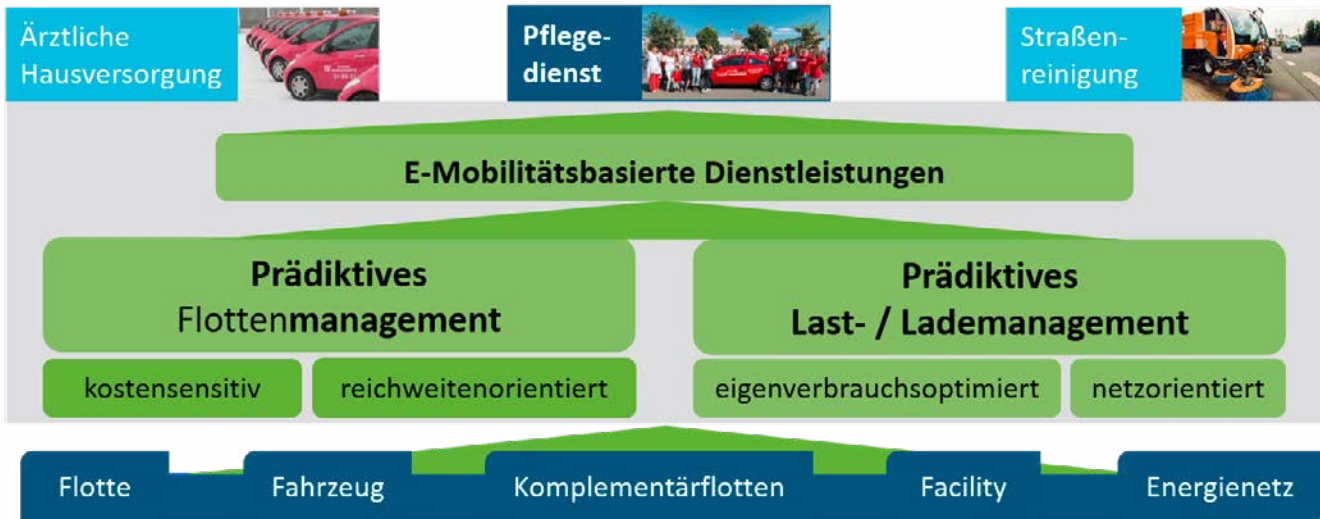

Source: Project sMobilityCOM

The approach

It is easier to achieve economic viability of the vehicles when usage-driven costs go down and mileage goes up since this shrinks the fixed cost per km. For electric vehicles, usage-driven costs are mostly determined through the cost of electricity. This can be reduced through optimised rostering of vehicles, variable electricity tariffs for mobile consumers and the careful use of locally generated electricity from renewables. To increase mileage, electric cars should be used in multiple ways, e.g. during the day by mobile care services, and during the night by security firms. The complete rostering of the vehicles is integrated into the existing planning of care services, resulting in an integrated predictive charging and scheduling management. The aspired ICT solution also controls the secondary usage.

Target users and benefits

Mobility-based service providers are able to significantly reduce the cost of their fleet. The associated CO₂ saving directly leads to an improved reputation.

Energy

The cost of electricity can be minimised through a variable electricity tariff for mobile consumers due to a privilege in the Energy Industry Act (§ 14a EnWG - reduced grid charges for interruptible consumers) as well as the dynamic integration of renewables at local and regional level. A predictive load and charging management with dynamic power control of the building supply ensures that electric vehicles can be safely integrated into the power grid and cost-intensive expansion of the grid connection capacity can be avoided. In addition, the system intelligently controls the phase balance in case of grid asymmetry and thus plays an active role in stabilising the grid.

Thanks to the integration with fleet management, vehicles are charged in a cost-effective way and are reliable ready for use according to demand.

Networked communication

As part of the project an integrated information and communication system for the operation of the vehicles is developed.

The mission management system communicates with energy, fleet and building energy management, with the grid and with all relevant components of fleet operation. Open interfaces allow an easy integration with external systems.

Opportunities for providers and users

More cost-effective fleets ensure the competitiveness of mobility-based services. Grid-compatible building connections ensure the integration of electric vehicles into the German electricity grid. Electricity suppliers are able to offer grid-compatible ecological tariffs for mobile consumers.



For further information:

www.smobility.net

Consortium partners

INNOMAN GmbH (Leader of the consortium), DAKO Systemtechnik und Service GmbH & Co. KG, envia Mitteldeutsche Energie AG, Fraunhofer IOSB-AST Institutsteil Angewandte Systemtechnik, MCS – MICRONIC Computer Systeme GmbH, HKW-Elektronik GmbH

UrbanMove



Inner-city mobility solution based on a service platform and emission-free autonomous PeopleMover

The challenge

Every day, motorized individual traffic, including a large number of urban commuters, causes significant noise and pollutant emissions and congestion. If vehicles were to stop on the outskirts and people were to continue their journey with shared zero emission taxis, air quality and quality of life as well as the flow of traffic could improve significantly. What is required is simple, zero emission and user-oriented mobility with almost no restrictions for people within low emission zones. UrbanMove accepts this challenge and will put a solution on the road by December 2020.

The approach

Autonomous electric shuttles, so-called PeopleMovers, are designed to take over passenger transport in inner cities. They enable travel from hubs, located at the outskirts of the city and well connected to long-distance traffic, to individual destinations.

Demand is determined by data from the city infrastructure, user behaviour and location and capacity of the buses. All data is collected on one platform, processed and forwarded to the individual participants in passenger transport.

Target users and benefits

The offer is aimed at commuters and people living within existing low emission zones. Adaptive pricing will make the PeopleMover an attractive option. Users benefit by eliminating time otherwise lost searching for parking and parking fees, as well as by direct and flexible arrivals and departures. Cities can “take a deep breath” due to reduced motorized individual traffic, less noise and congestion, better air and more space on the streets.

Energy

The backend calculates the vehicles’ charging time and location using data from planned trips and battery state-of-charge to maximize utilization while ensuring the highest possible service availability. After all, assured mobility is a top priority for users.

Networked communication

A service system collects data from the infrastructure, the PeopleMover, and customer demand. It then derives operational processes such as user management, booking, payment, vehicle energy management, and coordination with other services such as navigation and traffic data. The plat-

Illustration 22: Target image of UrbanMove: Collection, processing and forwarding of the different information streams in inner-city operation.

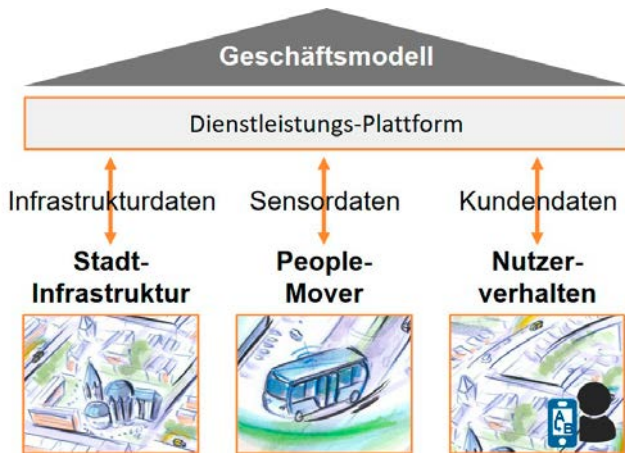

Source: Project UrbanMove

form users book and pay for their rides via smartphone app. Information about upcoming trips as well as departure and arrival points can be found through the app as well.

Opportunities for providers and users

PeopleMover offers tremendous and varied benefits for cities and people. Cities can reduce emissions and congestion and gain high-quality living space. Users reach their destinations more flexibly and make considerable savings in mobility costs through attractive pricing models. Even companies can “hop on” and integrate PeopleMover into their corporate mobility management. There is an almost infinite number of reasons and use cases for electric shuttles.



For further information:

<https://urbanmove.ac>

Consortium partners

e.GO Mobile AG (Leader of the consortium), Dialago AG, FIR e.V. an der RWTH Aachen, fleetbutler (Digital Mobility Solutions GmbH), Stadt Aachen

WINNER



WINNER - Integrated grid-neutral electric mobility in the housing industry in the neighbourhood and region

The Challenge

The housing industry in Chemnitz wants to support electric mobility and to increase the attractiveness of their properties through tenant tariff models. Especially considering the increasing risk of poverty in old age it is important to keep energy costs for tenants as low as possible for the long term. To meet climate political requirements, more renewables are to be used in the future. Demographic trends also demand a change of direction with regards to mobility models in housing estates in order to ensure an integrated provision for all residents. Between November 2016 and October 2019, a suitable approach is to be developed and implemented in a demonstrator.

The approach

WINNER combines local renewable energies in the properties, their use as energy supply in the neighbourhood (ten-

ant electricity) and supports the commercial and private use of electric mobility on site. To this end, overcapacities, fluctuations in capacity utilization and the respective grid status of the power grid are to be used intelligently. The integration of electric vehicles as energy storage devices can reduce the energy price in the residential complex by billing grid services, which is why charging/parking spaces are being built. The charging/parking spaces should also be accessible to mobility providers such as electric car sharing, and to care services and tradespeople who work in the buildings. Tenants should also have the option to hire electric vehicles for private use. The overall number of vehicles in the estate should decrease since electric car sharing removes the need for every resident to own a private vehicle. In an estate with eight blocks and a total of 280 residential units as well as other sites, four parking spaces with charging infrastructure will be created.



4. Supporting research

By connecting to existing networks such as the National Platform for Electric Mobility (NPE) and initiating new networks, the relevant players from research, business and politics are brought together.

As part of the supporting research of the technology programme “ICT for Electromobility III”, the VDE Verband der Elektrotechnik Elektronik Informationstechnik e. V. and the Deutsche Dialog Institut are supporting the technology projects on behalf of the BMWi in achieving their project goals. The focus of the accompanying research is on the following main areas of work:

- The scientific support provides support in the implementation of the projects in order to realize innovations in the sense of marketable products in a targeted manner.
- At the interfaces of systems integration in particular, the supporting research has the task of identifying new topics for research and development and promoting the establishment of new alliances. This includes the comparison with national and international technology developments and a utilization-oriented market observation.
- Another important task is to identify existing innovation hurdles, to develop proposals for overcoming them and to address and discuss recommendations for action to politics, business, science and society.
- In addition, actors from the funded projects with different industry and technology backgrounds are to be led to joint solutions to relevant cross-cutting issues, such as legal regulation, the handling of personal data (IT security, data security and data protection), the establishment of standards and norms and the development of new business fields. The opportunities and potentials of Germany as a location for electromobility - both in terms of technologies and their economic utilization through successful business models - should ultimately be communicated to a broad public.
- To this end, the transfer of knowledge and results must be organised and the projects and their progress communicated effectively to the public in order to promote acceptance of the results achieved.

The screenshot shows the website 'Digitale Technologien' with the following content:

- Header:** Logo of the Bundesministerium für Wirtschaft und Energie, navigation links (Über uns, Kontakt, EN), and a search bar.
- Navigation:** Fördersprogramme, Einzelprojekte, Termine, Service.
- Main Banner:** 'PAiCE - Digitale Technologien für die Wirtschaft' - Förderprogramm für digitale Innovationen in industriellen Wertschöpfungsprozessen.
- Aktuelle Meldungen:**
 - 12.09.2018: Bundesregierung startet KI-Expertenworkshops
 - 07.09.2018: IKT EM III-Projekte auf der New Mobility World/IAA
 - 20.08.2018: IKT EM III: Auswertung These des Monats Juli 2018
- Veranstaltungen:**
 - 18.06.2018 - 18.09.2018: Jetzt für Fed4FIRE+ bewerben
 - 13. - 14.09.2018: Förderprogramm Eurostars für forschungstreibende Unternehmen
 - 16. - 18.09.2018: Big Data Minds 2018
- Übersicht der Programme:** Includes a graphic with icons and text: 'Die Broschüre stellt die aktuellen Förderschwerpunkte zusammen und zeigt neueste Entwicklungen digitaler Technologien mit Blick in die Zukunft auf. Mehr'.
- Footer:** IKT für Elektromobilität, PAiCE, Publikationen.

Contact

ICT for Electric Mobility III Office
 Bismarckstraße 33
 10625 Berlin
 Tel.: 030 383868 - 30
 Fax: 030 383868 - 31
 geschaeftsstelle@ikt-em3.de
 www.digitale-technologien.de

